

SD95-16-G2



SD Department of Transportation
Office of Research



Rural Road Design, Maintenance, and Rehabilitation Guide

Prepared by
ERES Consultants, Inc.
505 West University
Champaign, IL 61820-3915

September 1995

DISCLAIMER

The contents of this report reflect the views of the authors who are responsible for the facts and accuracy of the data presented herein. The contents do not necessarily reflect the official views or policies of the South Dakota Department of Transportation, the State Transportation Commission, or the Federal Highway Administration. This report does not constitute a standard, specification, or regulation.

ACKNOWLEDGMENTS

This work was performed under the supervision of the SD95-16 Technical Panel:

Ray Roggow..... Gregory County
Roger Muller..... Turner County
Hiene Junge..... Codington County
Ken Skorseth...South Dakota Technology Transfer Center
Brett Hestdalen..... Federal Highway Administration
Toby Crow.....Office of Planning and Programming
Joe Feller..... Office of Materials and Surfacing
Terry JorgensenOffice of Local Government Assistance
David Huft..... Office of Research
Blair Lunde..... Office of Research

TECHNICAL REPORT STANDARD TITLE PAGE

1. Report No. SD95-16-G2	2. Government Accession No.	3. Recipient's Catalog No.	
4. Title and Subtitle Rural Road Design, Maintenance, and Rehabilitation Guide		5. Report Date September 22, 1995	
		6. Performing Organization Code	
7. Author(s) Mr. Curt A. Beckemeyer and Mr. Trent J. McPeak		8. Performing Organization Report No.	
9. Performing Organization Name and Address ERES Consultants, Inc. 505 West University Avenue Champaign, Illinois 61820-3915		10. Work Unit No.	
		11. Contract or Grant No. 310348	
12. Sponsoring Agency Name and Address South Dakota Department of Transportation Office of Research 700 East Broadway Avenue Pierre, SD 57501-2586		13. Type of Report and Period Covered Guideline	
		14. Sponsoring Agency Code	
15. Supplementary Notes The Rural Road Design, Maintenance, and Rehabilitation Guide (SD95-16-G2) is part of a series of three guides. The other two guides are the Rural Road Condition Survey Guide (SD95-16-G1) and the Rural Road Management Guide (SD95-16-G3).			
16. Abstract The <i>Rural Road Design, Maintenance, and Rehabilitation Guide</i> was developed to provide the counties of South Dakota with an established, uniform set of guidelines for the design, maintenance, and rehabilitation of rural roads. The guidelines address items such as roadway geometry (horizontal and vertical), typical roadway surface types, roadway surface design and repair, subgrade soils, and trench backfilling. The geometric-related guidelines are adapted from the SDDOT <i>Secondary & Off-System Road Plan</i> and the 1990 American Association of State Highway and Transportation Officials (AASHTO) manual, <i>A Policy on Geometric Design of Highways and Streets</i>. The geometry guidelines address design speed, roadway width, vertical grades, stopping sight distance, curvature, cross slope, superelevation, right-of-way (ROW) width, vertical clearance, and ditch slopes. The roadway surface-related guidelines pertain to the design, maintenance, and rehabilitation of the four types of roadway surfaces typically constructed on South Dakota's rural roads—gravel, blotter, asphalt concrete, and portland cement concrete. The guidelines describe the primary design and performance characteristics of each surface type, provide design thicknesses, identify various repair techniques, and discuss the applicability of each technique. In addition, guidelines for the inspection and testing of materials and construction activities are discussed.			
17. Keyword		18. Distribution Statement No restrictions. This document is available to the public from the sponsoring agency.	
19. Security Classification (of this report) Unclassified		Security Classification (of this page) Unclassified	21. No. of Pages 64
		22. Price n/a	

TABLE OF CONTENTS

	<u>Page</u>
1. INTRODUCTION.....	1
2. GEOMETRIC DESIGN.....	3
Introduction	3
Geometric Requirements.....	3
Design Speed	7
Width of Roadway	7
Vertical Grades	7
Stopping Sight Distance	7
Minimum Curve Radius/Maximum Degree of Curvature.....	7
Pavement Surface Crown	8
Superelevation.....	8
Right-of-Way (ROW) Width.....	8
Vertical Clearance	8
Inslope	9
3. TYPICAL ROADWAY SURFACE TYPES.....	11
Gravel-Surfaced Roads	11
Blotter (Chip Seal) Pavements.....	11
Asphalt Concrete Pavements	12
Portland Cement Concrete Pavements.....	14
PCC Pavement Types	14
Function of the Various Layers in a PCC Pavement.....	15
4. GRAVEL ROAD DESIGN AND REPAIR.....	17
Gravel Road Repair Options	17
Typical Gravel Road Repair Techniques	19
Surface Blading.....	19
Regraveling	21
Dust Control	21
Cleaning Ditches	21
New or Reconstructed Gravel Roads.....	22
Typical Gravel Road Repair Frequency	22

TABLE OF CONTENTS (continued)

		<u>Page</u>
5.	FLEXIBLE PAVEMENT DESIGN AND REPAIR	25
	Flexible Pavement Repair Options	25
	Flexible Pavements in Excellent Condition (Rating Value of 86 to 100)	27
	Flexible Pavements in Very Good Condition (Rating Value of 71 to 85).....	27
	Flexible Pavements in Good Condition (Rating Value of 56 to 70)	27
	Flexible Pavements in Fair Condition (Rating Value of 41 to 55)	28
	Flexible Pavements in Poor Condition (Rating Value of 26 to 40).....	28
	Flexible Pavements in Very Poor and Failed Condition (Rating Value of 0 to 25)	29
	Flexible Pavement Repair Techniques	29
	Crack Sealing	29
	Pothole Patching	32
	Patching of Alligator-Cracked Areas	32
	Surface Treatments	33
	AC Overlays.....	35
	Partial-Depth Removal and Replacement of the AC Layer	38
	New Construction or Reconstruction of Flexible Pavements.....	39
6.	RIGID PAVEMENT DESIGN AND REPAIR	43
	Jointed Plain Concrete Pavement Repair Options	43
	JPCP in Excellent Condition (Rating Value of 86 to 100)	43
	JPCP in Very Good Condition (Rating Value of 71 to 85)	45
	JPCP in Good Condition (Rating Value of 56 to 70)	45
	JPCP in Fair Condition (Rating Value of 41 to 55)	45
	JPCP in Poor Condition (Rating Value of 26 to 40)	46
	JPCP in Very Poor and Failed Condition (Rating Value of 0 to 25).....	46
	Jointed Plain Concrete Pavement Repair Techniques	46
	Joint and Crack Sealing	46
	Partial-Depth Spall Repair	48
	Full-Depth PCC Patches.....	49
	Diamond Grinding	50
	AC Overlays.....	50
	Crack and Seat or Break and Seat Followed by an AC Overlay	50
	New or Reconstructed JPCP	51
	Jointed Plain Concrete Pavement Joints	53
	Longitudinal Joint Spacing	53
	Transverse Joint Spacing.....	53
	Joint Design.....	54

TABLE OF CONTENTS (continued)

	<u>Page</u>
7. SUBGRADE SOILS	55
Design Considerations.....	55
Construction Considerations	57
Drainage.....	60
Swelling Soils	60
8. TRENCH BACKFILLING	61
9. REFERENCES	63
 APPENDIX A SDDOT JPCP JOINT DETAILS	

1. INTRODUCTION

This document is the second in a series of three manuals produced for the South Dakota Department of Transportation. It is intended for use by county superintendents and other county roadway agency personnel within the State of South Dakota for the efficient selection of maintenance, rehabilitation, and reconstruction alternatives for rural gravel, blotter, asphalt concrete (AC), and portland cement concrete (PCC) roads. The first manual, *Rural Road Condition Survey Guide*, provides a methodology for determining the condition of rural paved and gravel-surfaced roads. The third manual, *Rural Road Management Guide*, provides direction for establishing county-wide management systems for rural paved and gravel-surfaced roads.

The *Rural Road Design, Maintenance, and Rehabilitation Guide* was developed to provide the counties of South Dakota with an established, uniform set of guidelines for the design, maintenance, and rehabilitation of rural roads. The guidelines address items such as roadway geometry (horizontal and vertical), typical roadway surface types, roadway surface design and repair, subgrade soils, and trench backfilling.

The geometric-related guidelines are adapted from the SDDOT *Secondary & Off-System Road Plan* and the 1990 American Association of State Highway and Transportation Officials (AASHTO) manual, *A Policy on Geometric Design of Highways and Streets*. The geometry guidelines address design speed, roadway width, vertical grades, stopping sight distance, curvature, cross slope, superelevation, right-of-way (ROW) width, vertical clearance, and ditch slopes.

The roadway surface-related guidelines pertain to the design, maintenance, and rehabilitation of the four types of roadway surfaces typically constructed on South Dakota's rural roads – gravel, blotter, AC, and PCC. The guidelines describe the primary design and performance characteristics of each surface type, provide design thicknesses, identify various repair techniques, and discuss the applicability of each technique. In addition, guidelines for the inspection and testing of materials and construction activities are discussed.

2. GEOMETRIC DESIGN

2.1. Introduction

The geometric design guidelines presented in this section are adapted from the SDDOT *Secondary & Off-System Road Plan* agreement between the Federal Highway Administration (FHWA) and the South Dakota Department of Transportation, dated November 26, 1990. Where information on a certain topic was not available in the above reference, the AASHTO manual entitled *A Policy on the Geometric Design of Highways and Streets* (AASHTO 1990) was used. In general, the information contained in these two documents tends to agree very closely.

This section outlines a set of guidelines for the geometric design of local and collector rural roads. Because there are no rural arterial roads under local jurisdiction in South Dakota, guidelines on rural arterials are omitted from this document. It is important to note that these are guidelines and not mandatory standards. More detailed information on the design of rural roads may be found in the SDDOT *Secondary and Off-System Road Plan* and the AASHTO Geometric Guide.

The designer should make every effort to provide the best possible alignment, grade, adequate drainage, and sight distance consistent with the terrain, present and proposed development, and funds available to the agency. Please note that guidelines on signing and safety appurtenances are not included in this document. These guidelines are available from the SDDOT Office of Local Government Assistance (605-773-4831) and the South Dakota Transportation Technology Transfer (T³) Service. The South Dakota T³ Service has developed a document that summarizes the requirements of the *Manual on Uniform Traffic Control Devices (MUTCD)*. This document is available to the counties of South Dakota.

2.2. Geometric Requirements

The following 12 geometric-related items addressed in this document:

- Design speed.
- Roadway width.
- Vertical grades.
- Stopping sight distance.
- Pavement surface crown.
- Right-of-way width.
- Superelevation.
- Shoulder width.
- Minimum curve radius.
- Maximum degree of curvature.
- Vertical clearance.
- Inslope (foreslope).

A summary of the requirements for each of these items is provided in Tables 2.1 through 2.4 and the paragraphs following. An illustration of several of the items is provided in Figure 2.1. Information on other geometric-related items can be found in

Table 2.1. Summary of geometric design criteria for local rural roads.

ADT	Terrain	Design speed kph (mph)	Minimum traveled way, m (ft)	Shoulder width, m (ft)	Maximum vertical grade, %	Stopping sight distance, m (ft)	Minimum curve radius, m (ft)	Maximum degree of curvature	Vertical clearance, m (ft)	Maximum inslope
<50	Level	48.3 (30)	5.5 (18)	0.6 (2)	7	61 (200)	83.2 (273)	21.00	4.3 (14)	2:1
	Rolling	32.2 (20)	5.5 (18)	0.6 (2)	11	38 (125)	35.4 (116)	49.25	4.3 (14)	2:1
	Mountainous	32.2 (20)	5.5 (18)	0.6 (2)	16	38 (125)	35.4 (116)	49.25	4.3 (14)	2:1
50-250	Level	48.3 (30)	5.5 (18)	0.6 (2)	7	61 (200)	83.2 (273)	21.00	4.3 (14)	2:1
	Rolling	48.3 (30)	5.5 (18)	0.6 (2)	10	61 (200)	83.2 (273)	21.00	4.3 (14)	2:1
	Mountainous	32.2 (20)	5.5 (18)	0.6 (2)	16	38 (125)	35.4 (116)	49.25	4.3 (14)	2:1
250-400	Level	64.4 (40)	6.1 (20)	0.6 (2)	7	99 (325)	155.1 (509)	11.25	4.3 (14)	2:1
	Rolling	48.3 (30)	6.1 (20)	0.6 (2)	10	61 (200)	83.2 (273)	21.00	4.3 (14)	2:1
	Mountainous	32.2 (20)	6.1 (20)	0.6 (2)	16	38 (125)	35.4 (116)	49.25	4.3 (14)	2:1
> 400	Level	80.5 (50)	6.7 (22)	1.2 (4)	6	145 (475)	258.8 (849)	6.75	4.3 (14)	2:1
	Rolling	64.4 (40)	6.7 (22)	1.2 (4)	9	99 (325)	155.1 (509)	11.25	4.3 (14)	2:1
	Mountainous	48.3 (30)	6.1 (20)	1.2 (4)	14	61 (200)	83.2 (273)	21.00	4.3 (14)	2:1

Table 2.2. Summary of geometric design criteria for collector rural roads.

ADT	Terrain	Design speed kph (mph)	Minimum traveled way, m (ft)	Shoulder width, m (ft)	Maximum vertical grade, %	Stopping sight distance, m (ft)	Minimum curve radius, m (ft)	Maximum degree of curvature	Vertical clearance, m (ft)	Maximum inslope
<50	Level	64.4 (40)	6.1 (20)	0.6 (2)	7	99 (325)	155.1 (509)	11.25	4.3 (14)	3:1
	Rolling	48.3 (30)	6.1 (20)	0.6 (2)	9	61 (200)	83.2 (273)	21.00	4.3 (14)	3:1
	Mountainous	32.2 (20)	6.1 (20)	0.6 (2)	12	38 (125)	35.4 (116)	49.25	4.3 (14)	3:1
50-250	Level	64.4 (40)	6.1 (20)	0.6 (2)	7	99 (325)	155.1 (509)	11.25	4.3 (14)	3:1
	Rolling	48.3 (30)	6.1 (20)	0.6 (2)	9	61 (200)	83.2 (273)	21.00	4.3 (14)	3:1
	Mountainous	32.2 (20)	6.1 (20)	0.6 (2)	12	38 (125)	35.4 (116)	49.25	4.3 (14)	3:1
250-400	Level	64.4 (40)	6.1 (20)	0.6 (2)	7	99 (325)	155.1 (509)	11.25	4.3 (14)	3:1
	Rolling	48.3 (30)	6.1 (20)	0.6 (2)	9	61 (200)	83.2 (273)	21.00	4.3 (14)	3:1
	Mountainous	32.2 (20)	6.1 (20)	0.6 (2)	12	38 (125)	35.4 (116)	49.25	4.3 (14)	3:1
> 400	Level	80.5 (50)	6.7 (22)	1.2 (4)	6	145 (475)	258.8 (849)	6.75	4.3 (14)	3:1
	Rolling	64.4 (40)	6.7 (22)	1.2 (4)	8	99 (325)	155.1 (509)	11.25	4.3 (14)	3:1
	Mountainous	48.3 (30)	6.1 (20)	1.2 (4)	10	61 (200)	83.2 (273)	21.00	4.3 (14)	3:1

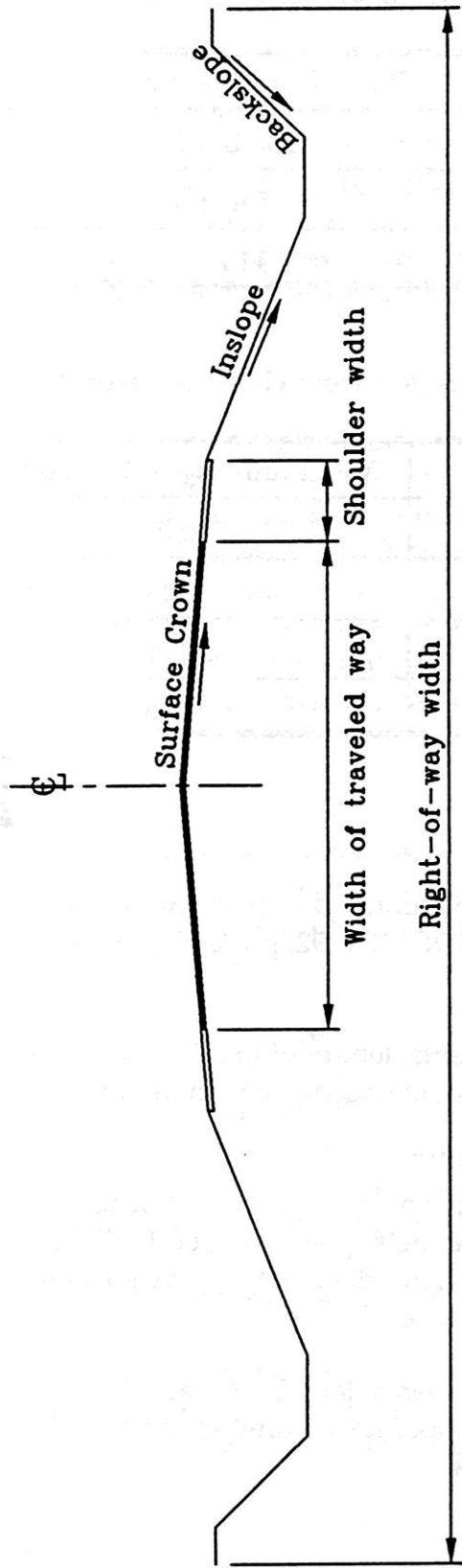

Figure 2.1 Typical pavement cross section.

Table 2.3. Surface crown requirements (local and collector roads).

Surface type	Rate of surface crown, %
High	1.5 to 2.0
Intermediate	1.5 to 3.0
Low	2.0 to 6.0

Table 2.4. Maximum superelevation rates (local and collector roads).

Rural road type	Pavement surface type	Maximum superelevation rate
Local	Paved	0.06
	Gravel	0.12
Collector	Paved	0.06
	Gravel	n/a

the AASHTO Geometric Guide.

In Tables 2.1 and 2.2, three types of terrain are identified – level, rolling, and mountainous. The SDDOT *Road Design Manual* (SDDOT 1992, pp. 2-7) provides the following definitions for the three types of terrain:

Level (flat) terrain: Any combination of gradients, length of grade, or horizontal or vertical alignment that permits trucks to maintain speeds that equal or approach the speeds of passenger cars.

Rolling terrain: Any combination of gradients, length of grade, or horizontal or vertical alignment that causes trucks to reduce their speeds substantially below that of passenger cars on some sections of highway, but does not involve sustained crawl speed by trucks for any substantial distance.

Mountainous terrain: Any combination of gradients, length of grade, or horizontal or vertical alignment that will cause trucks to operate at crawl speed for considerable distances or at frequent intervals.

2.2.1. *Design Speed*

Design speed is the maximum safe speed that can be maintained under favorable conditions and should be consistent with the speed a driver is likely to expect. Typically, the posted speed should be less than the design speed. Design speed influences a vehicle's stopping sight distance and side friction on curves. Lower design speeds are applicable to roads with winding alignment in rolling or mountainous terrain. Higher design speeds are applicable to roads in level terrain or where other environmental conditions are favorable.

2.2.2. *Width of Roadway*

The roadway width is defined as the combined width of the traveled way (trafficked area) and the shoulders. The minimum width of traveled way for rural roads is 5.5 m (18 ft), and the minimum shoulder width is 0.6 (2 ft). These minimum values are to be increased based on road classification, design speed, and traffic levels. By South Dakota statute, the minimum total roadway width is 6.7 m (22 ft). If there is significant truck traffic and there is a possibility that the road will receive improvements, including additional gravel or an asphalt overlay, it is strongly suggested that a wider roadway width be used.

2.2.3. *Vertical Grades*

The vertical grade of a roadway is defined as the ratio between the change in elevation over a change in length. Grades should be as level as practical, given the surrounding terrain. Adequate surface crown should be provided to drain water from the pavement surface.

2.2.4. *Stopping Sight Distance*

The length of roadway that is visible ahead of the driver should be long enough to enable a vehicle traveling at the design speed to stop before reaching a stationary object in the road. Stopping sight distance is directly related to design speed, higher design speed requires a longer stopping sight distance.

2.2.5. *Minimum Curve Radius/Maximum Degree of Curvature*

The allowable degree of curvature is determined from the design speed, superelevation, and side friction characteristics of the road in question. The degree of curvature is directly related to the curve radius by the following relationship:

$$D = \frac{5,729.6}{R}$$

(Eq. 2.1)

where

- D = Degree of curvature.
- R = Curve radius, ft.

2.2.6. *Pavement Surface Crown*

Pavement surface crown, or cross slope, should be adequate to provide proper surface drainage. The surface crown for rural roads typically ranges from 1.5 to 6.0 percent, depending on the pavement surface type. A summary of surface crown requirements is provided in Table 2.3. High-type pavements retain structural integrity and do not ravel if placed on a stable subgrade. The smoothness characteristics and proper crown of the surface enable drivers to steer easily and maintain a proper path. On the other hand, low-type pavements with raveled or loose surfaces, such as gravel, require greater steering effort to maintain a correct path. The surface type should be provided commensurate with the design speed selected for the road.

2.2.7. *Superelevation*

The maximum rates of superelevation usable on roadways are controlled by several factors, including pavement surface type, climate conditions, terrain conditions, and traffic usage. A superelevation rate of 0.12 may be used on low-volume gravel-surfaced roads to facilitate cross drainage; however, rates this high may cause higher travel speed, conducive to rutting and displacement of gravel. Superelevation rates greater than 0.06 should not be used for roads with paved surfaces (high- or intermediate-types).

2.2.8. *Right-of-Way (ROW) Width*

Right-of-way width adequate to accommodate the construction, proper drainage, and maintenance of the roadway should be obtained. A wide right-of-way permits construction of gentle slopes and widening or strengthening of the pavement as traffic increases.

2.2.9. *Vertical Clearance*

Vertical clearance at underpasses should be at least 4.3 m (14 ft) over the entire roadway width. It is a good idea to add 150 mm (6 in) to this height to allow future

pavement resurfacing. By South Dakota statute, the minimum vertical clearance is 4.6 m (15 ft) under railroads and 5.5m (18 ft) for utilities.

2.2.10. Inslope

Inslopes should be as gentle as feasible. Gentle inslopes increase safety by providing maneuvering area in emergencies, are more stable than steep slopes, aid in establishing plant growth, and simplify maintenance work. The maximum rate of inslope depends on the stability of local soils as determined by investigation and local experience, as well as available right-of-way width. The steepest inslope that should be used is 2:1 on local rural roads and 3:1 on rural collector roads.

3. TYPICAL ROADWAY SURFACE TYPES

Typically, a rural road is constructed with the type of surface consistent with the nature and volume of the traffic it accommodates. The four road surface types that are typically constructed in South Dakota's roads are:

- Gravel-surfaced.
- Blotter (chip seal).
- Asphalt concrete.
- Portland cement concrete.

A brief discussion of each pavement type is presented below.

3.1. Gravel-Surfaced Roads

Gravel roads are referred to as low-type surfaces because they usually serve low traffic volumes. This surface type provides the lowest level of service.

The basic structure of gravel roads consists of a gravel layer of adequate thickness and quality overlying the subgrade. The thickness of the gravel layer generally depends on traffic volume, quality of gravel available, and the existing soil or subgrade. Structurally, gravel-surfaced roads function as flexible pavements. Structural capacity is achieved by spreading the load over the weaker underlying soil (the subgrade). The basic principle in the thickness design of gravel roads is to provide an adequate thickness based on traffic volume and the strength of the subgrade such that the stress reaching the subgrade does not exceed the in-place strength of the subgrade. For most conditions, a minimum of 100 to 150 mm (4 to 6 in) of gravel is required.

3.2. Blotter (Chip Seal) Pavements

A blotter-surfaced road is considered an intermediate-type road. A blotter road consists of a surface treatment placed on a granular base. The surface treatment consists of a uniform application of asphalt cement to a road surface, followed immediately by a layer of aggregate chips. The surface treatment may be as thin as 6 mm (0.25 in) or as thick as 25 mm (1 in), depending on the size of the aggregate chips and the number of surface treatment applications.

On lightly traveled roads, blotters provide a relatively long-term, inexpensive pavement that does not dust, corrugate (washboard), or lose surface materials from the abrasive action of vehicle tires. However, on roads carrying heavier volumes of traffic (especially trucks), the blotter pavement provides only a comparatively short service life.

3.3. Asphalt Concrete Pavements

Asphalt concrete (AC) pavements are considered to be high-type pavements and are intended to serve intermediate to high traffic volumes or heavy wheel loads. Conventional AC pavements are layered systems, typically consisting of an asphalt concrete surface placed on one or more layers of bound or unbound granular materials, which in turn are placed on the existing subgrade soil. The various layers of a conventional AC pavement consist of the following material types and typical thicknesses:

- AC layer that is 50 to 150 mm (2.0 to 6.0 in) thick.
- Aggregate (gravel) base course that is 150 to 300 mm (6.0 to 12.0 in) thick.
- Compacted subgrade.

Figure 3.1 shows a typical cross section of a conventional AC pavement.

The basic principle supporting the design and performance of such layered pavement systems is to provide higher quality (stronger) materials in the top layers, where the stresses from vehicle loads are high, and to use lower quality (weaker) materials in the lower pavement layers, where stress intensities are much lower. For example, in Figure 3.1 the surface course should have the highest strength and the subgrade the lowest strength.

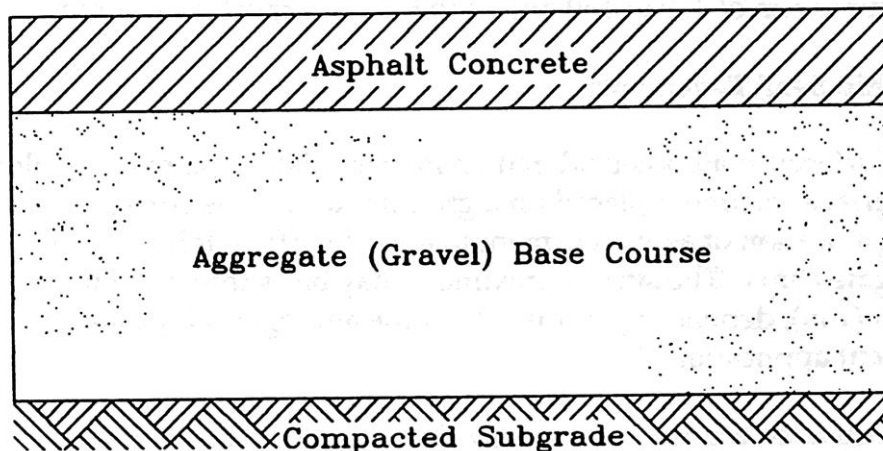

Figure 3.1. Typical cross section of a conventional AC pavement.

In a conventional AC pavement, the AC layer is intended to provide smooth rideability and good skid resistance, promote good pavement surface drainage, prevent moisture from infiltrating into the pavement structure, and protect the underlying base course layers from the high stresses that occur at the interface between the pavement surface and tires. Although the AC layer does provide some distribution of vehicle loads, the relative thinness of this layer limits its load-carrying capabilities. A majority of the load distribution occurs in the base course layer. Therefore, adequate layer thickness and material quality should be used in the base course layer to ensure that load-related stresses are sufficiently distributed and that the underlying subgrade is protected.

The two primary load-related failure modes of AC pavements are alligator cracking and pavement rutting. AC alligator cracking occurs when excessive tensile strains develop at the bottom of the AC layer. This form of cracking can best be minimized by providing adequate AC thickness and good underlying support. AC pavement rutting typically results from excessive vertical stresses on top of the subgrade or excessive shear stresses in the aggregate (gravel) base course. Again, adequate pavement thickness (both AC and base course) can minimize this rutting. Rutting can also occur in the AC or base course layer as a result of increased material densification under traffic. However, this type of rutting can be minimized through proper material specification and construction control. Significant amounts of rutting and alligator cracking can be expected if heavy trucks are allowed to travel on under-designed pavements.

Primary material- and AC mixture-related failure modes of AC pavements include asphalt stripping (separation of the asphalt from the aggregate), low-temperature cracking, and asphalt bleeding. These forms of deterioration generally occur as a result of poor material selection or improper AC mixture design. However, improper construction techniques, such as improper compaction, can cause or worsen these conditions. Although these forms of AC pavement deterioration are important to overall pavement performance, this guide focuses primarily on load-related distresses.

Full-depth AC pavements consist of one or more layers of AC placed directly on the subgrade or improved subgrade. In the State of South Dakota, poor pavement performance has been associated with this type of AC pavement. Therefore, the South Dakota Department of Transportation does not encourage the construction of full-depth AC pavements.

TYPICAL ROADWAY SURFACE TYPES

3.4. Portland Cement Concrete Pavements

3.4.1. PCC Pavement Types

Portland cement concrete (PCC) pavements are referred to as rigid pavements. The PCC is typically placed on an aggregate (gravel) base layer. A typical cross section of a PCC pavement is presented in Figure 3.2.

The types of concrete pavement that are typically constructed on rural roads include:

- Jointed plain concrete pavement (JPCP).
- Jointed reinforced concrete pavement (JRCP).

Continuously reinforced concrete pavement (CRCP) is another type of PCC pavement, but CRCP is rarely used on rural, low-volume roads.

The primary differences between JPCP and JRCP are associated with the use of slab reinforcement and the transverse joint spacing. JPCP has no reinforcement and a short (typically 4.6 m [15 ft] or less) transverse joint spacing. JRCP has reinforcing steel in the PCC to hold tightly together any cracks that form. Typically, the joint spacing in a JRCP is much greater (up to 15 m [50 ft]) than in a JPCP. Therefore, fewer joints are required in a JRCP, but the trade-off is the cost of the reinforcement.

Cracking in concrete pavements is caused by the combined effects of temperature and moisture changes and the effect of wheel loads. Transverse and longitudinal joints are provided in concrete pavements to control the locations of the cracking.

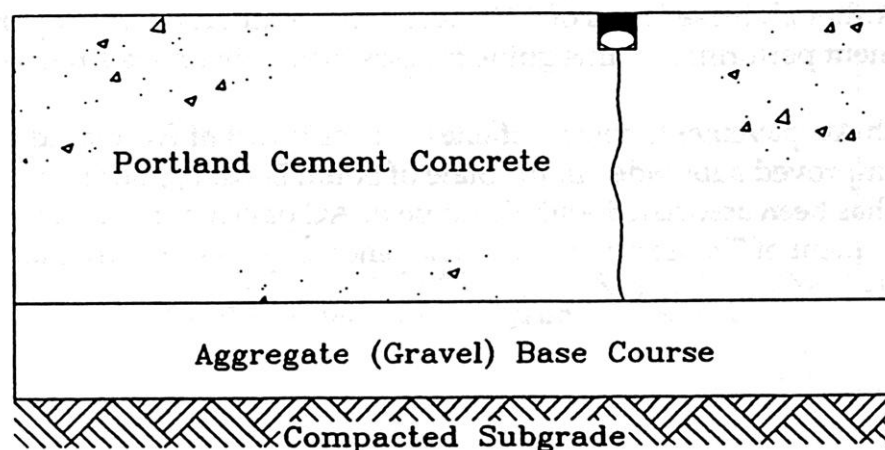

Figure 3.2. Typical cross section of a PCC pavement.

Load transfer across PCC joints is very important in reducing stresses at the joints. Aggregate interlock across a joint is typically the only form of load transfer in PCC rural roads, although this frequently results in joint faulting. Load transfer devices, such as dowel bars, can also be used to provide additional load transfer across a PCC joint. However, use of load transfer devices in thin PCC (less than 200-mm [8-in] thick slabs) can result in severe joint deterioration due to high stress concentrations around the devices. Because of the shortened life of under-designed PCC pavements and their costly rehabilitation, extreme caution should be used in constructing PCC slabs that are less than 200 mm (8.0 in) thick. Also, the SDDOT Office of Local Government Assistance (605-773-4831) should be consulted regarding aggregate sources, as some aggregates will contribute to premature PCC deterioration.

3.4.2. *Function of the Various Layers in a PCC Pavement*

The PCC surface layer performs two primary functions – it provides a smooth riding surface and significant load distribution over a relatively large area. In a properly designed PCC pavement, the vertical stress levels in the layers below the PCC are only a small fraction of those applied on the pavement surface. Due to the tremendous stiffness of the PCC layer (with respect to the underlying base and subgrade layers) the PCC layer provides a vast majority of the pavement's load-carrying capabilities. Therefore, the most effective way to reduce stresses (and hence, reduce cracking) in a PCC pavement is through increased PCC thickness. Increases in PCC strength or underlying base/subgrade support only have a minimal effect in reducing PCC stresses. However, this does not preclude the importance of the use of good bases and subgrades.

A base in a PCC pavement is provided directly under the concrete surfacing. Base material may either be of natural selected aggregate (gravel) or stabilized soil with emphasis on a minimum amount of fine-grained materials. One of the primary functions of a base is to prevent the pumping of these fine-grained subgrade materials from beneath the PCC layer. When pumping occurs, corner breaks, joint faulting, and slab cracking can be expected. The simultaneous existence of three factors – heavy traffic loads, pumpable fine-grained soils, and excessive subgrade moisture – can result in the pumping of fines. Where these three critical factors prevail, the use of a base under the PCC is highly encouraged. Other functions of PCC pavement bases include:

- Provide improved load transfer at pavement joints.
- Provide uniform support for the pavement.
- Provide a firm improved platform for pavement construction.
- Provide a drainage layer for water entering the pavement system.

The typical base layer thickness on a rural PCC pavement is 100 to 150 mm (4 to 6 in).

4. GRAVEL ROAD DESIGN AND REPAIR

4.1. Gravel Road Repair Options

Gravel surfacing is common on low-volume rural roads. If properly constructed and maintained, a gravel-surfaced road provides a low-cost structure that can more than adequately support low-volume traffic conditions. However, proper maintenance is the key to the performance of this roadway surface type.

Typically, in the maintenance and repair of a gravel-surfaced road, the following seven distresses/conditions must be addressed (Eaton and Beaucham 1992):

- Improper cross section. A properly crowned gravel pavement should have 100 to 150 mm (4.0 to 6.0 in) of crown, or slope, from its center to the edge.
- Inadequate roadside drainage.
- Corrugations.
- Dust.
- Potholes.
- Ruts.
- Loose aggregate.

Each of these seven distresses has three severity levels – low, medium, and high (Eaton and Beaucham 1992). Descriptions of the seven distresses and illustrations of the three severity levels for each distress are provided in the *Rural Road Condition Survey Guide*.

The types of repairs and maintenance that are recommended for a gravel-surfaced road are related to the types and severities of distresses evident in the pavement. A summary of the recommended gravel-surfaced roadway maintenance and repair options, along with the distress type and severity each addresses, is provided in Table 4.1. An illustration of the relationship between gravel road condition and the corresponding repair method(s) is provided in Figure 4.1.

GRAVEL ROAD DESIGN AND REPAIR

Table 4.1. Suggested gravel road repair alternatives (Eaton and Beaucham, 1992).

Distress type	Distress severity	Typical repair techniques
Improper gravel road surface crown	Low	Blade surface of roadway.
	Medium	Blade surface or blade surface and add material (water and aggregate), then recompact.
	High	Cut to subgrade, add aggregate, shape, add water, and compact.
Improper roadside drainage	Low	Clean ditches.
	Medium	Clean out culverts. Reshape, construct, and improve inslopes of ditches. Eliminate secondary ditches.
	High	Regrade ditches, construct special ditch grade, and raise the ditch grade line. The installation of larger culverts, ditch dams, rip rap, geotextiles, or underdrains may also be necessary.
Corrugations	Low	Blade surface.
	Medium	Blade surface or blade surface and add material (aggregate and water), then compact.
	High	Cut to subgrade, add new aggregate (or alter gradation), shape, add water, and compact.
Dust stabilization	Low	Add water to surface.
	Medium	Add a stabilizer (e.g., calcium chloride) to the surface.
	High	Increase stabilizer use – or – Cut to subgrade, add stabilizer, water, and compact – or – Cut to subgrade, add aggregate and stabilizer, shape, water, and compact. – or – Upgrade to a paved surface.

Table 4.1. Suggested gravel road repair alternatives (continued).

Distress type	Distress severity	Typical repair techniques
Potholes	Low	Blade surface of roadway.
	Medium	Blade surface or blade surface, add material (water, aggregate, or mix of calcium chloride and crushed gravel), and compact.
	High	Cut to subgrade, add aggregate, shape, add water, and compact.
Ruts	Low	Blade surface of roadway.
	Medium	Blade surface or blade surface, add material (water, aggregate, or mix of calcium chloride and crushed gravel), and compact.
	High	Cut to subgrade, add aggregate, shape, add water, and compact.
Loose aggregate	Low	Blade surface.
	Medium	Blade surface or blade surface, add material (restore gradation and water), and compact.
	High	Cut to subgrade, add new aggregate, shape, add water, and compact.

4.2. Typical Gravel Road Repair Techniques

4.2.1. Surface Blading

As illustrated in Table 4.1, blading of the gravel surface is periodically necessary to restore proper pavement crown and remove minor corrugations, potholes, and ruts. When blading a gravel road (especially in the spring or when adequate moisture is present), the top 50 to 100 mm (2.0 to 4.0 in) of gravel should be scarified and reshaped to provide the necessary crown and to eliminate the surface irregularities. When dry conditions exist, only light blading should be done, and care should be taken not to disturb any crust that exists.

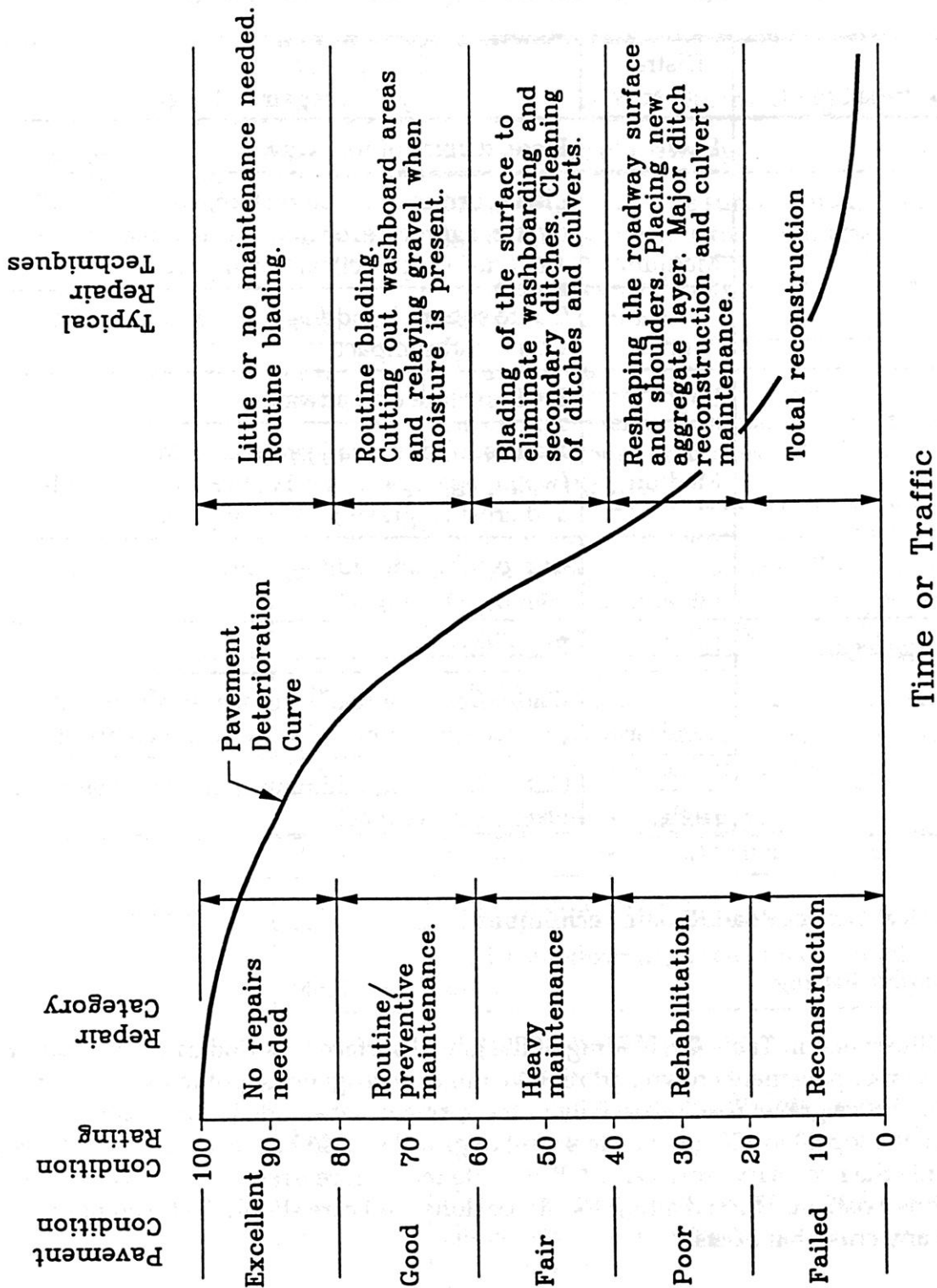

Figure 4.1 Relationship between gravel road condition and repair requirements.

4.2.2. Regraveling

Over time, the gravel layer thickness becomes significantly reduced due to dusting and the pushing of loose gravel to the shoulders and ditches. In these instances, it is necessary to add new gravel to the roadway surface. The aggregate material, whether for repair of an existing gravel-surfaced road or for a new gravel-surfaced road, should comply with the gradation and durability requirements outlined in section 882, *Aggregates for Granular Bases and Surfacing*, of the SDDOT Standard Specifications for Road and Bridge Construction. Regraveling thicknesses are typically in the range of 75 to 150 mm (3 to 6 in).

4.2.3. Dust Control

Rolling and compacting of a new gravel surface will help to maintain a tight and impervious surface that has few dusting problems. When dusting does occur, it can be minimized through the application of water or a stabilizing agent (calcium chloride or magnesium chloride) to the surface. The water will only provide a short-term solution and is seldom feasible except in special situations on short sections of road, whereas the stabilizing agent provides a more long-term solution.

Section 205, *Dust Control*, of the SDDOT Standard Specifications for Road and Bridge Construction, provides specifications for the application of either calcium chloride or magnesium chloride (magwater). A summary of these specifications is provided below.

1. The dust control chlorides should be uniformly applied under pressure in liquid form by mechanical equipment. The rate of application should be 0.65 kg/m² (1.2 lb/yd²) of pavement surface. This weight should be the anhydrous (free of water) weight of the chloride solution. The chloride material should comply with section 891, *Dust Oil and Dust Control Chlorides*, of the SDDOT Standard Specifications for Road and Bridge Construction.
2. The chloride should be blended into the top 25 to 50 mm (1 to 2 in) of the gravel surface.
3. The pavement surface should be tightly compacted. The addition of water may be necessary in order to adequately compact the material.

4.2.4. Cleaning Ditches

Roadside ditches play a substantial role in providing adequate drainage for a gravel road. It is important that the roadside ditches be properly shaped and sloped and remain free of vegetation and debris. The ditch bottom should always be below the subgrade elevation, and the longitudinal grade of the ditch should be 1 percent or more, if possible, to promote good drainage.

Ditches must periodically be cleaned to restore drainage. This work is typically performed with a motor grader. However, on some roads either the right-of-way is too limited or the ditch slope is too steep to allow the use of a motor grader. In these instances, an articulated, boom-mounted bucket can be used.

Erosion of ditches can also be a problem. To prevent erosion of ditches, one of the following techniques can be used:

- Lining the ditch with a geotextile and rock.
- Building ditch checks (dams) that reduce the velocity of the flow in the ditch.
- Letting grass grow in the bottom of the ditch.
- Widening the ditch to shallow the flow and reduce the velocity of the water flow.

4.2.5. *New or Reconstructed Gravel Roads*

The thickness of new aggregate-surfaced roads typically ranges from 150 to 375 mm (6 to 15 in). A gravel thickness of 75 to 150 mm (3 to 6 in) is very typical on South Dakota's rural gravel-surfaced roads.

The gravel layer thickness necessary is primarily dependent on the level of heavy truck traffic that uses the roadway and the strength of the subgrade. The desired level of gravel road performance is also a factor in determining the necessary gravel layer thickness. Obviously, the greater the desired level of performance the thicker the gravel layer should be.

Guidelines for selecting the appropriate gravel layer thickness are provided in table 4.2. These thicknesses were calculated using the design procedures presented in the 1993 American Association for State and Highway Transportation Officials (AASHTO) *Guide for the Design of Pavement Structures*. Table 4.2 identifies four truck traffic ranges and three subgrade strength ranges. These designs are based on a 5-year design life and 60 mm (2.5 in) of allowable rutting.

The suggested gravel layer thickness presented in Table 4.2 should be used as guidelines. Local experience and expertise should also be considered when selecting a gravel layer thickness. Also, please consult the SDDOT Office of Local Government Assistance (605-773-4831) for assistance in the design of a gravel road for a route that carries more than 50 heavy trucks per day.

4.3. Typical Gravel Road Repair Frequency

Unlike paved roads, gravel-surfaced roads require continual maintenance and repair efforts. On paved roads, maintenance activities typically occur on an annual or

biannual basis. On gravel-surfaced roads, maintenance activities are typically performed weekly, every few weeks, or every few months. Based on interviews with several South Dakota county highway agencies, the maintenance schedule outlined in Table 4.3 is commonly used.

Table 4.2. Suggested gravel layer thicknesses for new or reconstructed rural roads.

Estimated daily no. of heavy trucks	Subgrade support condition ¹	Suggested minimum gravel layer thickness, mm (in)
0 to 5	Low	165 (6.5)
	Medium	140 (5.5)
	High	115 (4.5)
5 to 10	Low	215 (8.5)
	Medium	180 (7.0)
	High	140 (5.5)
10 to 25	Low	290 (11.5)
	Medium	230 (9.0)
	High	180 (7.0)
25 to 50	Low	370 (14.5)
	Medium	290 (11.5)
	High	215 (8.5)

Notes. ¹ Low subgrade support: average CBR \leq 3 percent; medium subgrade support: 3 percent < average CBR \leq 10 percent; high subgrade support: average CBR > 10 percent. ² CBR = California Bearing Ratio of the in-place subgrade soils. Methods of estimating CBR are discussed in section 7 of this document.

Table 4.3. Gravel road maintenance guidelines.

ADT	ADTT	Terrain	Gravel frequency, years	Blading frequency, per month
≥ 50	High	Level	4	4
		Rolling	5	4
		Mountainous	4	4
	Low	Level	7	3
		Rolling	7	3
		Mountainous	6	3
< 50	Low	Level	5	2
		Rolling	7	2
		Mountainous	6	2

ADT = average daily traffic. ADTT = average daily truck traffic.

5. FLEXIBLE PAVEMENT DESIGN AND REPAIR

5.1. Flexible Pavement Repair Options

This section identifies the techniques that are typically used to repair flexible pavements in each of the seven pavement condition categories listed below. For the purpose of this guide, flexible pavements include both AC and blotter pavements.

<u>Condition</u> <u>Category</u>	<u>Rating</u> <u>Value Range</u>
Excellent	100 to 86
Very Good	85 to 71
Good	70 to 56
Fair	55 to 41
Poor	40 to 26
Very Poor	25 to 11
Failed	10 to 0

The intent of this section is to identify the different pavement repair techniques and briefly discuss when application of each of the repair techniques is appropriate. Discussion of specific details of each of the identified repair techniques is provided later in this section. The identified repair techniques primarily address pavement-related deterioration and deficiencies. The techniques do not specifically address geometric-related deficiencies, although in some instances both concerns will be addressed (i.e., correction of AC rutting and insufficient pavement cross slope through partial depth replacement of the AC layer).

As the condition of a flexible pavement changes, so does the pavement's repair needs. For flexible pavements in excellent condition, minimal amounts of crack sealing are all that is typically needed. However, for significantly deteriorated flexible pavements, much more expensive repairs, such as full-depth patching, AC overlays, or complete reconstruction, may be necessary.

An illustration of the relationship between flexible pavement condition and the corresponding repair method(s) is provided in Figure 5.1. As seen in this figure, a delay in repairing a pavement can result in significantly greater repair requirements. If not properly maintained, a pavement can deteriorate to a condition where low-cost maintenance activities are no longer effective.

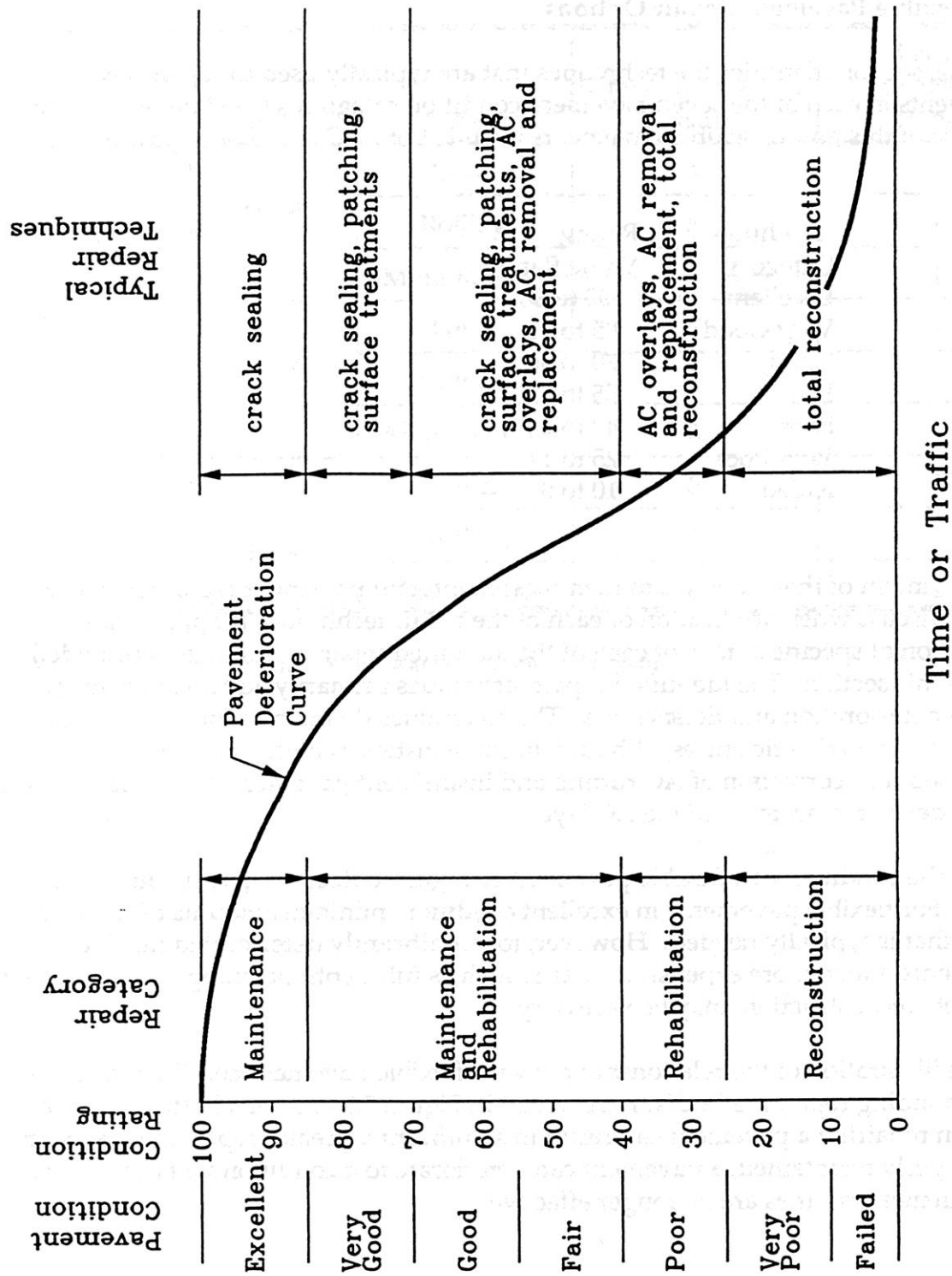

Figure 5.1. Relationship between flexible pavement condition and repair requirements.

5.1.1. Flexible Pavements in Excellent Condition (Rating Value of 86 to 100)

Flexible pavements in excellent condition typically consist of newly-constructed or well-maintained pavements that are in sound structural condition. Typically, the only distresses (if any) in a flexible pavement in excellent condition are minor hairline cracks and minor depressions.

Repairs to flexible pavements in excellent condition typically consist of maintenance activities, such as crack sealing. When sealing cracks in a flexible pavement, it is recommended that all visible cracks be routed and sealed. Leaving cracks unsealed, especially as they become wider, can lead to water infiltration and accelerated pavement deterioration.

5.1.2. Flexible Pavements in Very Good Condition (Rating Value of 71 to 85)

The surface of a flexible pavement with a condition rating of 71 to 85 may be partially oxidized or weathered. Also, low- to medium-severity cracking may be present. However, the cracks are generally very tight.

Crack sealing is also the primary form of maintenance performed on flexible pavements in very good condition. As previously noted, it is recommended that all visible cracks be routed and sealed when performing crack-sealing operations. In addition to crack sealing, application of a surface treatment may be appropriate if the pavement surface is substantially weathered or oxidized. Also, full-depth patching should be performed in alligator-cracked and potholed areas.

5.1.3. Flexible Pavements in Good Condition (Rating Value of 56 to 70)

Flexible pavements in good condition typically exhibit noticeable amounts of surface oxidation and raveling. Transverse and longitudinal cracks are typically between 6 and 13 mm (0.25 and 0.5 in) wide. Alligator cracking may begin to be present in the wheelpaths, and rutting of the wheelpaths is becoming more pronounced.

Maintenance and minor rehabilitation activities are typically required on flexible pavements in good condition. Crack sealing should still be performed, and alligator-cracked and potholed areas should be patched full-depth. If surface oxidation or raveling is significant, a surface treatment may be appropriate. If rutting is a problem, placement of a thin (38 to 50 mm [1.5 to 2.0 in]), nonstructural AC overlay is recommended.

5.1.4. Flexible Pavements in Fair Condition (Rating Value of 41 to 55)

Pavement deterioration is becoming more advanced in flexible pavements in fair condition. Block cracking is common, and weathering of the AC surface is quite noticeable. The cracks are generally greater than 13 mm (0.5 in) wide, and deterioration of the cracks is prevalent. Rutting in the wheelpaths is more pronounced and may be over 13 mm (0.5 in) deep. Areas of medium- to high-severity alligator cracking may also be present in the wheelpaths.

For flexible pavements in fair condition, minor to major rehabilitation is typically required. The appropriate form of repair is highly dependent on the types of distresses present. Scenarios of different pavement conditions and suggested repairs are discussed below.

Scenario 1: If the pavement distresses are not predominantly load related (e.g., minimal amounts of alligator cracking and rutting) and primarily consist of longitudinal, transverse, and block cracking, an appropriate form of repair includes sealing cracks, full-depth patching of any alligator-cracked and potholed areas, and placement of a thin (38 to 50 mm [1.5 to 2.0 in]) AC overlay. Partial-depth removal of the AC layer may be necessary to accommodate grade constraints, such as overpass clearance requirements, that cannot be overlaid.

Scenario 2: If only minor amounts of alligator cracking are evident and the AC surface is either significantly oxidized or rutted, repair should include the partial-depth removal (milling) and replacement of the AC surface.

Scenario 3: If alligator cracking is evident over much of the pavement, especially the wheelpaths, complete removal and replacement of the AC layer is suggested. If the alligator cracking occurred over a typical pavement service life (20 years or more) and similar traffic conditions are expected, placement of a similar thickness of AC is most likely sufficient. However, if the alligator cracking occurred over a shorter time period or substantially higher truck volumes are anticipated, a greater thickness of AC is needed. If the base thickness is inadequate, pulverizing the in-place AC and combining it with the upper portion of the underlying base course before placing a new AC wearing course should be considered.

5.1.5. Flexible Pavements in Poor Condition (Rating Value of 26 to 40)

Flexible pavements with this condition rating are badly deteriorated. Severe alligator cracking is common, with pieces of AC missing and potholes present. Rutting is also common on flexible pavements in this condition, and the pavement's rideability is typically poor.

Flexible pavements in this condition generally require major rehabilitation. The repair techniques discussed in Scenario 3 are typically appropriate. However, if significant quantities of the underlying base and subgrade require stabilization prior to placement of the new AC layer(s), it may be more appropriate to perform complete reconstruction. The actual percentage of base course/subgrade stabilization at which total reconstruction becomes more cost-effective will vary from county to county, depending on actual construction costs.

5.1.6. Flexible Pavements in Very Poor and Failed Condition (Rating Value of 0 to 25)

Flexible pavements in either very poor or failed condition have reached a condition level in which traffic operation is difficult. Potholes and alligator cracking are extensive, and rut depths may exceed 20 mm (0.75 in). Complete reconstruction is the only appropriate means of pavement repair.

5.2. Flexible Pavement Repair Techniques

5.2.1. Crack Sealing

The purpose of sealing cracks in a flexible pavement is to minimize the amount of water entering the pavement system through the pavement surface and to minimize the amount of deterioration (spalling, additional cracking) along the edges of cracks.

Procedures: There are many methods of sealing (or filling) cracks in a flexible pavement. An illustration of some of these methods is provided in Figure 5.2. One of the easiest and cheapest methods is to simply blow debris out of the cracks with an air compressor and fill the cracks with a suitable hot-pour asphalt sealant (method A in Figure 5.2). Unfortunately, use of this method typically results in poor crack sealant performance. More elaborate methods of crack sealing can include crack routing, backer rod placement, use of high-quality sealant materials, and placement of a sealant overband. These advanced methods obviously cost more initially, but the increased sealant performance and life generally offset the increase in initial cost.

The SDDOT currently specifies the use of the standard recessed band-aid method (method E) for AC-surfaced pavements. SDDOT experience is that the sealant configuration has performed as well as any method in the State of South Dakota. However, in locations of heavy pedestrian use or turning vehicles, placement of the overband is not recommended. During summer months, the sun-heated sealant will be picked up by pedestrians and turning vehicles. Therefore, the use of the standard reservoir-and-flush configuration (method D) is recommended.

The results of a recent national study on flexible pavement joint sealants indicated that both methods D and E exhibited very good performance characteristics. Therefore,

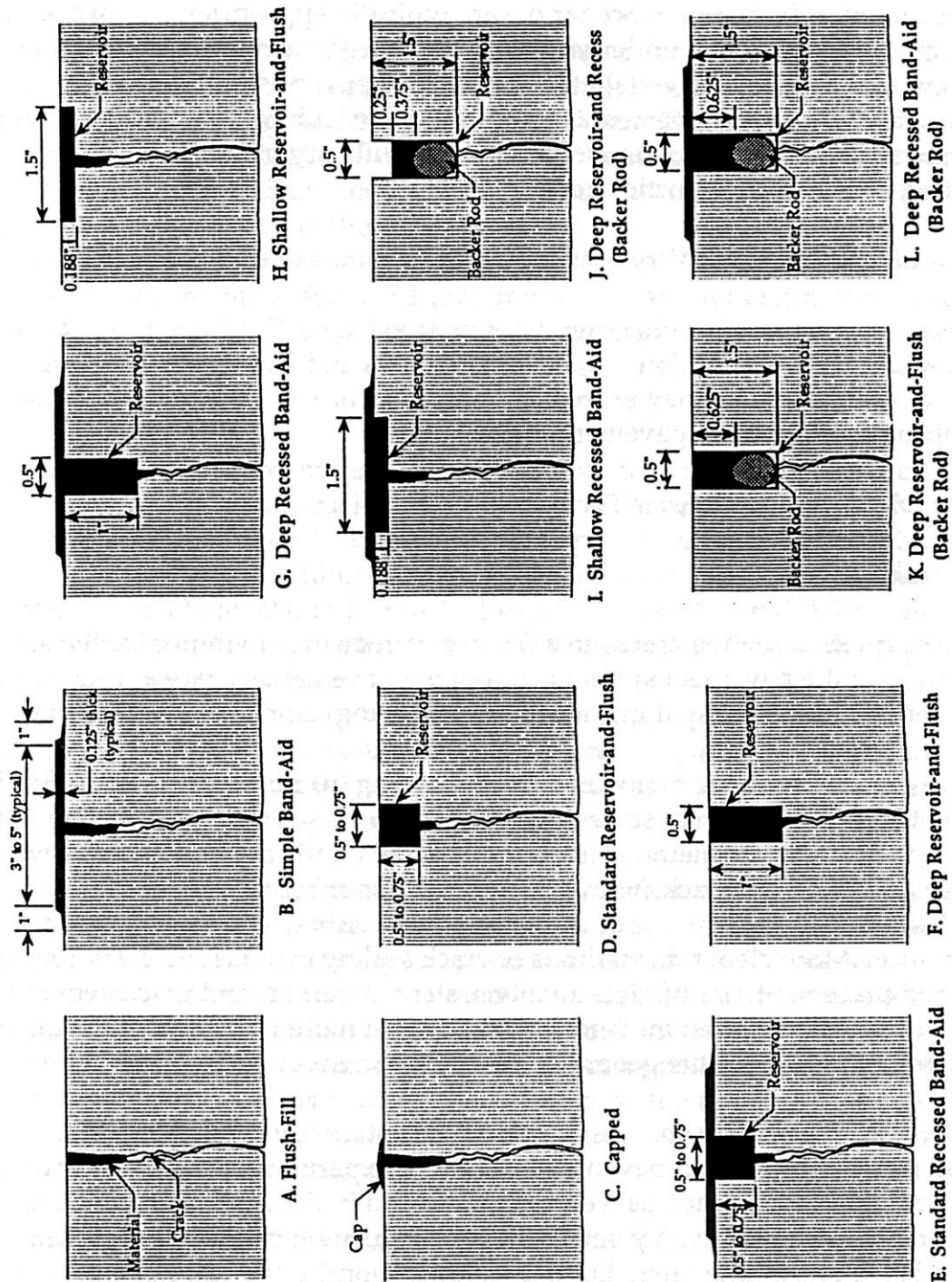

Figure 5.2. Typical crack sealant configurations (ERES Consultants, Inc. 1993).

unless the sealant is only needed to perform for 1 year or less (e.g., an overlay is to be placed over the pavement in the very near future), use of the standard reservoir-and-flush configuration is recommended.

The recommended procedures for sealing cracks in AC-surfaced pavements are provided in the SDDOT Performance Standard Function 2112, Rout and Seal Cracks. Although not outlined in this standard, it is common practice in the State of South Dakota to seal all visible cracks in the pavement surface. A summary of the procedures outlined in Function 2112 is provided below. As previously discussed, the placement of a sealant overband (specified in Function 2112) is not recommended for areas of high pedestrian traffic or turning vehicles.

1. Cracks should be routed with a star bit router or random crack saw. The routed channel should be 20 mm (0.75 in) wide and 20 mm (0.75 in) deep. Cracks greater than 20 mm (0.75 in) wide during the summer months will not require routing but should be thoroughly cleaned to a depth equal to the crack width.
2. An inert compressible material (e.g., backer rod) should be inserted along the bottom of cracks deeper than 20 mm (3/4 in). The material should be positioned such that the sealant depth will be equal to the crack width.
3. The channel shall be thoroughly cleaned of all dust, dirt, and loose materials with oil-free compressed air immediately before sealant application.
4. The channel shall be overfilled with sealant and shall be squeegeed with a U-shaped device that treats the roadway surface 25 to 75 mm (1 to 3 in) on each side of the channel.
5. In areas of high pedestrian traffic or turning vehicles, the channel shall be filled with sealant so that the sealant is flush with the pavement surface.

For blotter pavements, a less elaborate means of sealing cracks is recommended. Crack routing is generally not effective on these pavements; the routing operation typically chips the surface treatment. Therefore, on blotter pavements, either method A or method C is recommended, and method C is preferred. For both of these methods, it is imperative that the crack be thoroughly cleaned with oil-free compressed air.

Materials: For sealing cracks in flexible (blotter and AC-surfaced) pavements, the SDDOT requires the use of a rubberized asphalt sealant (hot-pour) meeting the requirements of the American Society for Testing and Materials (ASTM) Test Designation D 3405. Several manufacturers produce sealants that meet these requirements.

5.2.2. *Pothole Patching*

Potholes create a significant hazard to the traveling public. Extensive vehicle damage and personal injury can result when a vehicle hits a pothole. Therefore, patching of potholes, regardless of the overall pavement condition, is necessary.

Procedures: To restore smooth rideability, potholes should be permanently patched in accordance with SDDOT Performance Standard Function 2101, Patching with Premix. The procedures outlined in this specification are summarized below.

1. Remove all loose and unstable material from the pothole (normally not more than 305 mm [12 in] deep).
2. Make sure the hole and surrounding area are dry.
3. Provide vertical faces along the sides of the hole.
4. Apply a very light tack coat of asphalt to all exposed surfaces in the hole.
5. Place the bituminous premix in lifts. The uncompacted thickness of each lift should not exceed 65 mm (2.5 in).
6. Compact each lift by hand, truck wheels, or mechanical compactors prior to placement of additional lifts.
7. Construct the top of the patch to an elevation slightly higher (not more than 6 mm [0.25 in]) than the surrounding surface. This will allow for minor settlement of the patch under traffic.

Materials: Pothole patching can be done with a standard cold-mix material or with a high-quality proprietary material. The standard cold-mix material will typically provide a relatively short (less than 1 year) service life. The higher quality material may provide up to 3 years of service life, depending on the care taken during installation. As expected, the higher quality material is more expensive.

Standard cold-mix patching materials can be obtained from most asphalt concrete suppliers. The SDDOT does not publish specified cold-mix mixture requirements (aggregate gradation, percent asphalt). However, the SDDOT typically uses the same aggregate gradations outlined in the SDDOT hot-mix specifications, replacing the asphalt cement with a cutback asphalt and reducing the percentage of asphalt by 1 to 2 percent. High Performance Cold Mix, produced by Unique Paving Materials (UPM), and QPR 2000, produced by U.S. Pro-Tech, are two of the more popular proprietary cold-mix materials.

5.2.3. *Patching of Alligator-Cracked Areas*

Alligator-cracked areas are an indication of structural deterioration of the pavement as a result of traffic loadings. If unaddressed, these areas can quickly deteriorate under

additional traffic loadings, creating potential hazards (i.e., potholes) and increasing the size of the area to be repaired.

Identification of areas to be patched: Areas that exhibit moderate- to high- severity alligator cracking should be patched. In addition, areas of low-severity alligator cracking that visibly deflect under traffic loadings should be patched.

Identification of low-severity cracked areas that require patching can be easily accomplished through proofrolling of the pavement surface with a heavily loaded truck. A truck with either an 80 kN (18,000 lb) single axle load or a 144 kN (32,000 lb) dual axle load should be sufficient to proofroll rural roads. Areas that visibly deflect more than 2.5 mm (0.10 in) should be patched.

Procedures: To perform patching of alligator cracked areas the following basic procedures should be followed:

1. Remove the existing AC (or surface treatment) layers. Cold milling is an effective method of removing these layers.
2. Remove the underlying base/subbase materials to a depth equal to that of the previously removed AC layer or until the subgrade is reached, whichever is the lesser. The purpose of this is to provide a new AC layer that is thicker than the existing alligator-cracked area. The selection of an AC patch thickness that is twice the existing AC thickness is arbitrary and can be modified based on local experience.
3. Provide vertical faces along the perimeter of the removal area.
4. Apply a light tack coat of asphalt cement on the exposed surface of the patch area.
5. Reconstruct the patch area with plant-mixed asphalt concrete. The asphalt concrete materials, mixtures, layer thicknesses, and placement procedures should comply with section 320, Asphalt Concrete, General, of the SDDOT Standard Specifications for Road and Bridge Construction.

5.2.4. Surface Treatments

Surface treatments are typically constructed by applying a layer of asphalt cement that is covered with a layer of aggregate. Depending on the size of aggregate, surface treatments can vary in thickness from 6 to 20 mm (0.25 to 0.75 in). The thicker surface treatments generally consist of multiple (double or triple) applications of asphalt and aggregate.

Surface treatments are also a commonly used pavement rehabilitation technique. Surface treatments provide increased skid resistance, reduce the infiltration of water

through the pavement surface, minimize raveling of the existing surface, and minimize the oxidation of the underlying asphalt materials.

Procedures: The recommended procedures for applying surface treatments are outlined in section 360, Asphalt Surface Treatment, of the SDDOT Standard Specifications for Road and Bridge Construction. A similar specification is provided in SDDOT Performance Standard Function 2107, Seal Coating. A summary of the procedures outlined in this specification is provided below, along with pertinent SDDOT material specifications. For additional information in applying blotter surfaces and surface treatments, please contact the South Dakota Technology Transfer Center.

1. Seal coating with either asphalt cutbacks or emulsified asphalts should not be performed when the air temperature is below 10°C (50°F). However, when possible, a minimum air temperature of 16 °C (60 °F) is recommended.
2. Clean the existing surface of all foreign material.
3. If the existing surface is gravel (such as in blotter pavement construction), apply an asphalt prime coat to the gravel surface.
4. Apply a uniform application of asphalt. Typically the asphalt should be spread at a rate of 1.1 to 2.2 liter/m² (0.25 to 0.50 gallons per yd²). The asphalt should comply with section 890, Asphalt Material, of the SDDOT Standard Specifications for Road and Bridge Construction.
5. Apply a uniform application 11 to 25 kg/m² (20 to 45 lb per yd²) of cover aggregate immediately after application of the asphalt. The cover aggregate should comply with section 881 of the SDDOT Transportation Standard Specifications for Road and Bridge Construction.
6. Roll the sealed area immediately with a rubber tire roller. If a roller is not available, the wheels of a loaded truck are acceptable. Three complete coverages should be made. The roller speed should not exceed 8 kph (5 mph).
7. Newly sealed areas should be broomed lightly the following morning to remove loose aggregate. A second brooming should be performed within 2 to 4 days of the first.

Additional notes: Cutback asphalts are asphalt cements that have been cut back (diluted) with a liquid distillate (gasoline, kerosene, or diesel). As the distillate evaporates, the asphalt becomes more viscous (stiffer). The use of cutback asphalts has been restricted due to environmental concerns. Asphalt emulsions are mixtures in which small globules of asphalt cement are dispersed in water by means of an emulsifier (soap-like material). An emulsion is brown in color when first applied, and it is critical that the aggregate is placed while the emulsion is still brown. Shortly after placement, the water evaporates and the emulsion "sets" or "breaks," turns black, and leaves a continuous film of asphalt on the aggregate. When the emulsion breaks, it is too late to apply the aggregate. When using emulsified asphalts, the compatibility of the aggregate and the asphalt must be verified. Otherwise, asphalt stripping may

occur. Additional information on compatibility of emulsified asphalts and aggregates can be obtained from material suppliers and the SDDOT.

In general, a well-designed surface treatment will have approximately 50 to 70 percent of the aggregate embedded in the asphalt, with 30 to 50 percent of the aggregate exposed above the asphalt layer.

Typically, one-sized aggregate chips are best for surface treatment work. However, one-sized aggregate may not be available in all areas. If not, care should be taken to ensure that the aggregate does not contain a significant amount of fines because the fines reduce the effective amount of asphalt to such a low amount that the asphalt is not capable of bonding to the aggregates. An excess of fines will also soak up the asphalt material, reducing the bonding and waterproofing capability of the treatment.

Construction inspection: The application of a surface treatment should begin only after the materials and equipment have been thoroughly inspected. The work should also be closely monitored to ensure quality. Key points of inspection include the following.

1. Surface inspection.
2. Calibration of equipment.
 - Asphalt distributor.
 - Aggregate spreader.
3. Control and determination of quantities of asphalt and aggregate applied.
4. Timeliness of the construction sequence.
 - Application of asphalt.
 - Application of aggregate.
 - Initiation and completion of rolling.
 - Sweeping after completion.
5. Continued quality control of the materials.

5.2.5. AC Overlays

General: AC overlays may be constructed over existing surface treatments or existing AC pavements. AC overlays may be necessary to correct structural deficiencies (e.g., insufficient pavement thickness) or to improve a pavement's functional characteristics (e.g., skid resistance, rideability, cross slope).

Prior to placing an AC overlay, alligator-cracked areas should be patched and pavement cracks should be routed and sealed. Immediately prior to placing the overlay, the existing pavement surface should be swept clean of foreign and loose materials, and an asphalt tack coat should be applied to the pavement surface. The tack coat will promote bonding between the overlay and the existing pavement.

Thickness requirements: Most AC overlays constructed on South Dakota's existing AC-surfaced rural roads are functional overlays that are approximately 38 to 50 mm (1.5 to 2.0 in) thick. The 38 to 50 mm (1.5 to 2.0 in) thickness is generally the minimum thickness of AC that can be properly placed. AC thicknesses should always be at least twice the diameter of the maximum aggregate size in the AC mixture, and in most AC mixtures, a 20- to 25-mm (0.75- to 1.0-in) diameter maximum aggregate size is used.

There are instances when more than a minimum-thickness functional overlay is required on an existing AC-surfaced road. Also, an overlay thickness greater than 20 to 25 mm (0.75 to 1.0 in) is necessary on an existing blotter road in order to achieve good pavement performance. In these situations, the required overlay thickness is dependent on the condition and structural capacity of the existing pavement, as well as the forecasted level of traffic. A simple method of determining the required AC overlay thickness is through the use of the following equation:

$$ACOL = 2.5 SN - 2.5 C_d [0.40 H_{AC} + 0.14 H_{AGG}] \quad (\text{Eq. 5.1})$$

where

- ACOL = Required AC overlay thickness, in.
- SN = Required pavement structural number obtained from Table 5.1 in section 5.2.7 of this document. Please refer to Table 5.1 for discussion of the assumptions used in calculating the required SN.
- C_d = Existing pavement condition index (0.90 for pavement in overall good condition, 0.80 for pavement in overall fair condition, and 0.70 for pavement in poor condition).
- H_{AC} = Existing AC thickness, in.
- H_{AGG} = Existing aggregate base thickness, in.

This equation is a simplified application of the AASHTO pavement design procedures.

AC mix design: Quality pavements begin with quality mix design. Several elements should be considered when designing an asphalt concrete mix. These include aggregates, asphalt cement, and various properties of the asphalt concrete mixture.

Generally, aggregates should be cubical in shape, rather than flat, thin, or elongated. Angular-shaped particles provide greater interlock and internal friction, resulting in greater stability. Rounded particles, such as natural gravels and sand, provide less stable mixtures. Project specifications should indicate the required percentage of fractured faces for both fine and coarse aggregates. Aggregates not having a sufficient amount of fractured faces tend to have low stability and are prone to excessive rutting.

Aggregate gradation is a primary consideration in all asphalt concrete mix design. Coarse aggregates, fine aggregates, and mineral filler should be blended to achieve a proper gradation. Aggregate gradations should be dense-graded, yet still contain sufficient void space to permit enough asphalt cement for durability, while still leaving some air space to avoid bleeding and/or rutting. Use of excessive fines should be avoided. These excess fines can result in mixes which are too densely graded and do not allow sufficient air void space. Mixtures high in fines may also be more sensitive to slight changes in asphalt content.

The proper grade of asphalt cement must be selected to ensure adequate performance. This selection is based largely upon geographical location and the type of mixture being designed. In colder climates, such as in South Dakota, lower viscosity asphalts (such as an AC-10 or AC-5) should be considered to avoid low-temperature cracking.

Optimum asphalt content is determined through laboratory testing using either the Marshall criteria or other design methods (e.g., Hveem and SHRP). Optimum asphalt content is generally determined by finding the asphalt content which corresponds to the median air void content (typically 4 percent) of the specifications. Other mix design parameters such as stability, flow, and voids in mineral aggregate (VMA) are then checked against the specifications and the mix is either accepted or redesigned if necessary.

Air void content is one of the more critical parameters in mix design. The air void content in the compacted dense-graded mixture is usually suggested to be between 3 and 5 percent. If the void content is too low, the result is reduced intergranular contact and lower shear resistance, which can lead to rutting or bleeding problems. Air void contents which are too high result in a mix which is more permeable to air and water than is desirable, allowing for premature oxidation or stripping of the asphalt cement. It is essential that proper void content be achieved in the field through compactive effort only and not through increased asphalt cement content.

Construction inspection: In asphalt concrete overlay construction there are several key areas of concern, including surface preparation (cleanliness and tack coating), AC mixture control, AC mixture temperature control, placement, compaction, jointing, and protection. Many of these items require laboratory or field testing, whereas others only require visual inspection.

Prior to placing an AC overlay, alligator-cracked areas should be patched and pavement cracks should be routed and sealed. Immediately prior to placing the overlay, the existing pavement surface should be swept clean of foreign and loose materials, and an asphalt tack coat should be applied to the pavement surface.

The use of SDDOT-approved asphalt concrete mixtures is highly recommended, and aggregate gradation and asphalt cement content testing should be routinely performed to ensure that the specified mixture is actually being provided. In addition, the certification of the asphalt cement should be monitored.

The temperature of the asphalt concrete mixture should be checked immediately before it is placed. Too high a temperature can cause the asphalt material to burn, and too low a temperature will prevent proper compaction of the mixture. The asphalt concrete mixture should be placed at a temperature within $\pm 11^{\circ}\text{C}$ (20°F) of the mixture temperature specified in the job-mix formula. Typically, the job-mix formula mixture temperature ranges from 125 to 150°C (260 to 300°F).

The asphalt concrete should be placed in lifts approximately 38 to 76 mm (1.5 to 3.0 in) thick, depending on the maximum aggregate size. The use of an insufficient lift thickness can result in the fracturing of aggregates during compaction, and the use of an excessive lift thickness can prevent adequate compaction of the asphalt concrete. The lift thickness should be at least twice the diameter of the largest aggregate in the mixture. The density, air void content, and asphalt content of the compacted, in-place asphalt concrete should be continuously monitored throughout a project.

Asphalt concrete should not be placed when the underlying layer is frozen, the ambient air temperature is below 7°C (45°F), or after October 15. Asphalt concrete should also not be placed when it is raining or when rain is imminent.

A complete explanation of the necessary controls in AC construction is beyond the scope of this document. However, users are encouraged to review the SDDOT Standard Specifications for Road and Bridge Construction, the Asphalt Institute's (1983) Manual Series No. 22, *Principles of Construction of Hot-Mix Asphalt Pavements*, and other related documents.

5.2.6. Partial-Depth Removal and Replacement of the AC Layer

This form of flexible pavement repair is limited to AC-surfaced pavements and involves the partial-depth or complete removal and replacement of the existing AC layer. The AC removal can easily be accomplished through cold milling. Milling is extremely effective in removing pavement ruts or correcting improper cross slopes. Most cold milling machines have grade controls that allow the existing AC to either be milled to a constant depth or at a particular grade. Additional information on milling is provided in section 332, Cold Milling Asphalt, of the SDDOT Standard Specifications for Road and Bridge Construction.

As previously discussed, the depth of existing AC that is removed is dependent on the condition of the existing AC material and the types of distress that are present. If

only minor amounts of alligator cracking are evident and the AC surface is either significantly oxidized or rutted, repair should include the partial-depth removal (milling) of the AC surface, sealing of any remaining visible cracks, full-depth patching of alligator-cracked and potholed areas, and placement of a new AC layer of equal or greater thickness. The actual required thickness can be determined using Equation 5.1 and Table 5.1 (section 5.2.7).

If alligator cracking is evident over much of the pavement, especially the wheelpaths, complete removal and replacement of the AC layer is suggested. If the alligator cracking occurred over a typical pavement service life (20 years or more) and similar traffic conditions are expected, placement of a similar thickness of AC is most likely sufficient. However, if the alligator cracking occurred over a shorter time or if substantially higher truck volumes are anticipated, a greater thickness of AC is needed. Again, the required AC thickness can be determined using Equation 1 and Table 5.1.

Prior to placement of the new AC layer, any unstable areas of base course, subbase, and subgrade should be addressed. Identification of unstable areas can most efficiently be accomplished through proofrolling with a heavily loaded truck that has either an 80-kN (18,000-lb) single rear axle load or a 144-kN (32,000-lb) tandem rear axle load. Areas that visibly deflect under these specified load conditions are generally not stable enough to properly support asphalt paving operations and should be stabilized. Both wheelpaths of each traffic lane should be proofrolled the entire length of the construction area.

Construction inspection: Refer to section 5.2.5 of this document.

5.2.7. New Construction or Reconstruction of Flexible Pavements

A new flexible pavement can consist of either a blotter or an asphalt-surfaced pavement. For this document, a blotter pavement consists of a surface treatment (or series of surface treatments) placed on a granular base. An asphalt-surfaced road is composed of AC surface and binder courses constructed on a granular base.

Blotter pavement: For most counties in South Dakota, the typical blotter pavement consists of 6 to 10 in of aggregate base covered with a surface treatment. The aggregate base should be crushed, dense-graded material that complies with section 882 of the SDDOT Standard Specifications for Road and Bridge Construction. The aggregate base course should be compacted in accordance with section 260, Granular Bases and Surfacing, of the SDDOT Standard Specifications for Road and Bridge Construction. Adequate compaction increases the strength and durability of the layer and increases the layer's resistance to rutting and moisture.

The surface treatment layer should be applied as outlined in either section 360, Asphalt Surface Treatment, of the SDDOT Standard Specifications for Road and Bridge Construction or in SDDOT Performance Standard Function 2107, Seal Coating. Section 5.2.4 above summarizes the surface treatment application procedures.

AC pavement: For new or reconstructed AC rural roads in South Dakota, the typical pavement section is 50 to 150 mm (2.0 to 6.0 in) of AC on a 150- to 250-mm (6.0- to 10.0-in) thick aggregate base course. The layer thicknesses that are necessary for a specific county will be dependent on traffic volumes (primarily trucks), subgrade support conditions, and the desired pavement design life. In Table 5.1, the suggested pavement thicknesses for a range of traffic and subgrade conditions are provided. The thicknesses presented in Table 5.1 were calculated using the current AASHTO pavement design procedures and are based on a 20-year initial design life and a design reliability level of 75 percent. Additional pavement life can be achieved by providing future AC overlays. The structural coefficients used for the aggregate and asphalt concrete layers are 0.10 and 0.36, respectively.

The thickness guidelines presented in Table 5.1 are limited to rural roads that have fewer than 200 heavy trucks per day in the design lane of traffic. If truck traffic volumes are greater, the SDDOT Office of Local Government Assistance (605-773-4831) should be consulted and a detailed pavement design should be performed.

As seen in Table 5.1, there are several combinations of AC and aggregate base that can be used. The SDDOT's preference is to use the combinations with a thin AC layer and a thick base. The SDDOT's experience is that by using a thinner asphalt section the thermal cracking and stripping at the cracks is minimized. Also, the use of a thicker base may prevent the need to reconstruct the base and limit rehabilitation work to the AC layer.

Construction inspection: In new blotter or AC pavement construction, it is imperative that the subgrade and base course be properly placed. Proper compaction of subgrade soils is necessary to ensure good pavement performance. In general, all subgrade soils should be compacted to at least 95 percent of maximum dry density as determined by the SDDOT standard test procedure SD 104, at no less than 4 percentage points below optimum moisture. Unstable areas should be excavated and replaced with gravel or other suitable material. Additional information on subgrade preparation is provided in section 7 of this document.

Aggregate (gravel) base material should be placed in lifts no greater than 100 mm (4.0 in) thick. In general, aggregate base materials should be compacted to at least 97 percent of the maximum dry density determined in SDDOT standard test procedure SD 104.

Please refer to sections 5.2.4 and 5.2.5 of this document for suggested construction inspection activities during placement of blotter surfaces and asphalt concrete layers.

Table 5.1. Suggested AC-Surfaced Pavement Thicknesses.

Road classification and estimated daily truck traffic	Subgrade support conditions ¹	AASHTO structural number	Aggregate base thickness (in)	Corresponding AC layer thickness (in)
Light truck traffic (0 to 15 heavy trucks per day in design lane)	Low	2.89	6.0, 8.0, or 10.0	6.5, 6.0, or 5.5
	Medium	2.42	6.0, 8.0, or 10.0	5.0, 4.5, or 4.0
	High	1.88	6.0, 8.0, or 10.0	3.5, 3.0, or 2.5
Medium truck traffic (15 to 50 heavy trucks per day in design lane)	Low	3.44	8.0, 10.0, or 12.0	7.5, 7.0, or 6.5
	Medium	2.90	8.0, 10.0, or 12.0	6.0, 5.5, or 5.0
	High	2.27	8.0, 10.0, or 12.0	4.0, 3.5, or 3.0
Heavy truck traffic (50 to 200 heavy trucks per day in design lane)	Low	4.19	10.0, 12.0, or 14.0	9.0, 8.5, or 8.0
	Medium	3.55	10.0, 12.0, or 14.0	7.0, 6.5, or 6.0
	High	2.82	10.0, 12.0, or 14.0	5.0, 4.5, or 4.0

Notes. ¹Low subgrade support: average CBR² ≤ 3%; medium subgrade support: 3% < average CBR ≤ 10%; high subgrade support: average CBR > 10%. ²CBR = California Bearing Ratio (CBR) of the in place subgrade soils. Methods of estimating the CBR of a subgrade soil are provided in section 7 of this document.

6. RIGID PAVEMENT DESIGN AND REPAIR

This section identifies the techniques that are typically used to repair JPCP in each of the seven pavement condition categories listed below.

Condition <u>Category</u>	Rating <u>Value Range</u>
Excellent	100 to 86
Very Good	85 to 71
Good	70 to 56
Fair	55 to 41
Poor	40 to 26
Very Poor	25 to 11
Failed	10 to 0

The intent of this section is to identify the different pavement repair techniques and briefly discuss when application of each of the repair techniques is appropriate. More detailed discussions on the specifics of each of the identified repair techniques is provided later in this guide.

The identified repair techniques primarily address pavement-related deterioration and deficiencies. The techniques do not specifically address geometric deficiencies, although in some instances both concerns will be addressed. Also, repair techniques primarily address load-related JPCP distresses, such as cracking and joint faulting. However, some of the repair techniques for load-related distresses are also applicable for certain types of material-related distresses.

6.1. Jointed Plain Concrete Pavement Repair Options

Just as is the case for flexible pavements, JPCP repair needs increase tremendously as the condition of the pavement deteriorates. In fact, prolonged delay in maintenance and rehabilitation can be even more costly in JPCP. An illustration of the relationship between JPCP condition and the corresponding repair method(s) is provided in Figure 6.1. As seen in this figure, a delay in repairing a pavement can result in significantly greater repair requirements.

6.1.1. JPCP in Excellent Condition (Rating Value of 86 to 100)

A JPCP in excellent condition is typically a new pavement that exhibits no distresses, with the exception of some isolated hairline cracks. In general, due to the lack of distresses (including the absence of sealant deterioration), maintenance is not required on JPCP in this condition.

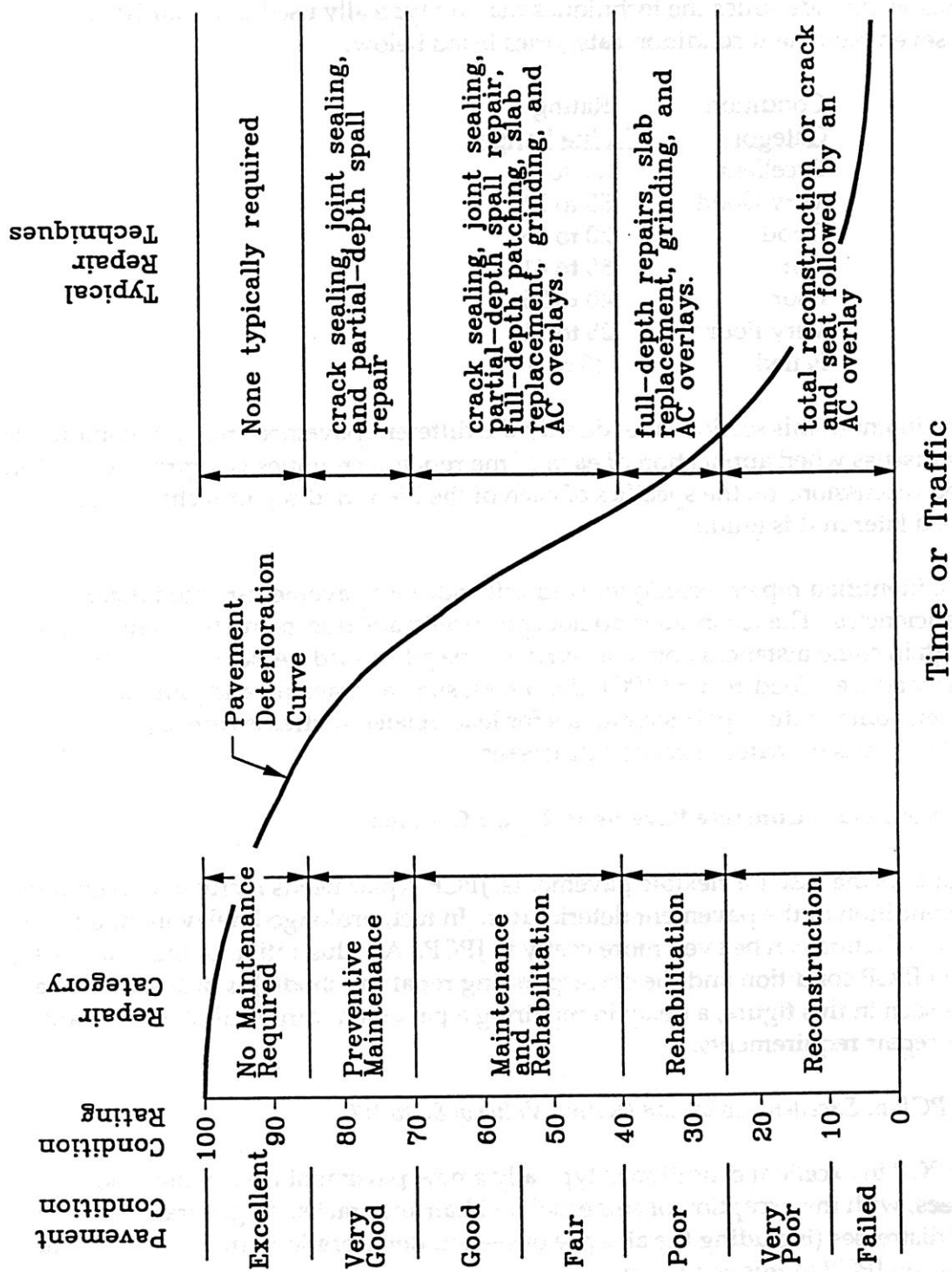

Figure 6.1. Relationship between JPCP condition and repair requirements.

6.1.2. JPCP in Very Good Condition (Rating Value of 71 to 85)

JPCP in very good condition may exhibit up to 7.5 m (25 ft) of cracking in a 90 m² (1,000 ft²) pavement area. The majority of the cracks are generally very tight. However, some of the cracks may be as much as 6 mm (0.25 in) wide. Other evident distresses may include PCC spalling at the joints and joint sealant deterioration.

Repairs to JPCP in this condition may be considered preventive maintenance. Repair activities include crack sealing, joint sealing, and partial-depth spall repair.

6.1.3. JPCP in Good Condition (Rating Value of 56 to 70)

JPCP in good condition may exhibit from 7.5 to 23 m (25 to 75 ft) of cracking in a 90 m² (1,000 ft²) area. However, unlike JPCP in very good condition, these cracks are typically 6 mm (0.25 in) wide. In addition, some spalling and faulting along the cracks and joints is typical of JPCP in this condition. Also, some corner breaks may be present, and scaling and D-cracking of the PCC may exist.

In addition to the maintenance activities of crack/joint sealing and partial-depth spall repair, rehabilitation activities such as full-depth patching, slab replacement, and grinding may be necessary. However, the quantities of these repairs should be relatively minimal. D-cracking (if present) is typically of low severity in pavements in this condition and generally does not warrant repair.

6.1.4. JPCP in Fair Condition (Rating Value of 41 to 55)

In JPCP in fair condition, the presence of cracks, patches, and joint/crack spalling is common. The patching may be extensive, and the patches may be exhibiting some severe deterioration. In many instances, transverse joint faulting is becoming quite evident to the traveling public when the pavement reaches this condition. Corner breaks may also be present in a JPCP in fair overall condition.

Preventive maintenance activities, such as joint/crack sealing and partial-depth spall repair should be continued on JPCP in fair condition. However, many of the necessary repairs will require minor to major pavement rehabilitation. These rehabilitation activities include full-depth patching, slab replacement, pavement grinding, and placement of an AC overlay. The reflection of PCC joints and cracks into the AC overlay is a common problem in AC-overlaid PCC pavements.

6.1.5. JPCP in Poor Condition (Rating Value of 26 to 40)

A JPCP in poor condition is typically in need of extensive full-depth patching and, in some cases, slab replacement. Extensive slab cracking is typical, and shattered slabs (slab cracked into four or more pieces) are not uncommon. Often, transverse joint faulting is significant and quite evident to the traveling public. If low-durability aggregates were utilized in the PCC mixture during construction, advanced stages of D-cracking can be expected in JPCP in poor condition.

Maintenance of JPCP in poor condition can include the repair of partial-depth spalls along joints and cracks. Crack and joint sealing may still be appropriate, depending on the overall pavement condition. However, for significantly deteriorated pavements, the beneficial effects of crack and joint sealing will be minimal.

Major rehabilitation is generally required on JPCP in poor condition. The recommended pavement rehabilitation activities are similar to those for JPCP in fair condition, but somewhat greater repair quantities should be expected. Typical repair techniques for JPCP in poor condition include full-depth repairs, slab replacement, pavement grinding, and AC overlay construction. Another rehabilitation option for PCC pavements in poor condition is crack and seat. This technique consists of cracking the existing PCC pavement into smaller pieces (roughly 0.4 to 0.6 m² [4 to 6 ft²]), seating the broken pavement into the underlying base or subgrade with a heavy roller, and overlaying the seated pavement with AC.

6.1.6. JPCP in Very Poor and Failed Condition (Rating Value of 0 to 25)

A JPCP in this condition is so severely deteriorated that neither maintenance nor rehabilitation is appropriate. Generally at least 50 percent of the total number of PCC slabs are cracked, and rideability is very poor.

Typically, the recommended repair technique for JPCP in very poor to failed condition is complete reconstruction. Maintenance and rehabilitation activities are generally ineffective in a JPCP in this condition. Crack and seat can also be an appropriate rehabilitation technique for a PCC pavement in very poor condition.

6.2. Jointed Plain Concrete Pavement Repair Techniques

6.2.1. Joint and Crack Sealing

The sealing of joints and cracks in JPCP serves two functions. First, the sealing minimizes the amount of water entering the pavement system. Second, the sealant prevents incompressible materials (e.g., sand and gravel) from infiltrating the joints/cracks and causing subsequent spalling, disintegration, and blow ups.

Crack sealing should normally be done when the cracks are open the widest. The time of the year when joint sealing is performed is less critical, and the sealing operations may be scheduled during periods of slack time.

Procedures: The SDDOT currently recommends that joints and cracks in concrete pavements be sealed in accordance with SDDOT Performance Standard Function 2135, Sealing Transverse Contraction Joints, Longitudinal Joints, and Cracks in Portland Cement Concrete Pavement (PCCP) with Silicone. A summary of these procedures is provided below.

Joints

1. Both faces of the joint should be cleaned of old sealant, oil, asphalt, curing compound, paint, rust, and other foreign materials prior to the installation of the sealant by one or a combination of several of the following methods: re-sawing, routing, sandblasting, high-pressure water, or compressed air.
2. Joints that do not comply with the width requirements of Function 2135 should be sawed to the specified width.
3. If the cleaning method used in Step 1 results in a cement/water film or slurry, the joint should be immediately flushed with water to remove the residue.
4. The joint should be sandblasted and cleaned with compressed air to remove all traces of dust immediately prior to sealant installation.
5. The joint must be dry at the time of sealant installation. The silicone sealant will not bond to a wet joint face, and immediate failure of the sealant will occur.
6. Backer rod comprised of inert, non-moisture absorbing, and resilient material that is approximately 3 mm (1/8 in) larger in diameter than the width of the joint should be installed in the joint. The backer rod should be installed so as to produce a 2 to 1 width/depth sealant shape factor.
7. The sealant should be placed under pressure with a mechanical device that has a nozzle that is shaped to fit into the joint and introduce the sealant from inside the joint.
8. The sealant should be tooled to ensure contact between the joint faces and the sealant.
9. The sealant recess below the pavement surface, sealant thickness, and backer rod diameter should comply with the requirements of Function 2135.

Cracks

1. If the crack is less than 13 mm (0.5 in) wide, it should be routed to the specified transverse joint width (dependent on slab size) outlined in Function 2135. The routing will also remove old sealant, oil, asphalt, and other foreign materials.
2. If the crack is wider than 13 mm (0.5 in), both crack faces should be thoroughly cleaned by one or more of the following methods: sandblasting, high pressure water jet, wire brushing, and compressed air.
3. All residue from the crack face cleaning operations should be flushed with water.
4. The crack should be sandblasted and cleaned with compressed air immediately prior to sealant installation to remove all traces of dust.
5. The crack must be dry when the sealant is installed. The silicone sealant will not bond to a wet surface, and immediate failure of the sealant will occur if the crack faces are wet.
6. Backer rod comprised of inert, non-moisture absorbing, and resilient material that is approximately 3 mm (1/8 in) larger in diameter than the crack that is to be sealed should be installed so as to produce a 2 to 1 width/depth sealant shape factor.
7. The sealant should be placed under pressure with a mechanical device that has a nozzle shaped to fit into the crack and introduce the sealant from inside the joint.
8. The sealant should be tooled to ensure contact between the crack faces and the sealant.
9. The finished thickness of the sealant should be no more than 13 mm (1/2 in) and no less than 6 mm (1/4 in).

Materials: The sealant should be a one-part, low modulus silicone. Please consult the SDDOT for the latest list of acceptable products.

6.2.2. *Partial-Depth Spall Repair*

The repair of partial-depth spalls in PCC pavements is intended to restore rideability and prevent the further deterioration of the pavement in the area of the spall. Small spalled areas can easily be patched with an epoxy mortar. However, for larger areas, it is generally more cost-effective to use low-slump concrete.

The SDDOT currently recommends that PCC pavement spalls be repaired in accordance with SDDOT Performance Standard Function 2125, Portland Cement Concrete Surface Repair. This standard identifies the necessary spall repair procedures, and addresses the use of either low-slump PCC or epoxy mortar. A summary of the recommended procedures follows:

1. Identify spalled areas with a chain drag, hammer, or steel rod to determine the limits of the unsound PCC. A hollow sound will be heard on spalled, deteriorated PCC, whereas a solid ringing sound will be emitted by intact PCC.
2. When using low-slump PCC, mark off the repair areas with straight lines and avoid corners with angles less than 90°. Sawcut along the perimeter of the repair area to a depth of at least 25 mm (1 in) and not more than 75 mm (3 in). This step is not necessary when using epoxy mortars.
3. Loosen the concrete with light jackhammers, taking care not to chip any sawcut edges.
4. Chip the spalled area down to sound concrete. Leave the non-sawcut surfaces rough to promote bonding between the pavement and the patching material.
5. Clean all exposed surfaces thoroughly by sandblasting, followed by compressed air.
6. Mop or brush a coat of sand grout (for low-slump PCC) or straight epoxy (for epoxy mortar) on the exposed surfaces.
7. Fill the repair area with the selected patching material.
8. Provide joints to match those of the existing pavement (if necessary). All joints should be subsequently sealed with a low-modulus silicone sealant.

Materials: The low-slump PCC should consist of a mixture composed of 1-1/2 parts cement, 2 parts sand, 2 parts rock, and enough water to produce a stiff mix with a slump of 13 to 25 mm (0.5 to 1.0 in). Type III cement is recommended, but Type I or IA may also be used. An air entraining agent must also be added to the mix. The maximum aggregate size of the sand should be no more than 9 mm (3/8 in), and the maximum aggregate size of the rock should not exceed 20 mm (3/4 in).

There are several suppliers of acceptable epoxy mortars. Please contact the SDDOT Office of Local Government Assistance (605-773-4831) for guidance in the selection of epoxy mortar materials.

6.2.3. Full-Depth PCC Patches

Jointed concrete pavements on which the deterioration is limited to the joints or cracks are generally good candidates for full-depth repairs. Full-depth repairs can be cost-effective and provide a significant increase in pavement service life if they are properly designed and installed. A critical parameter in full-depth repairs is the provision of adequate load transfer between the patch and the existing pavement.

Dowel bars, tie bars, and aggregate interlock are three methods of providing load transfer. The SDDOT recommends the use of tie bars in all full-depth PCC patches. These recommendations are outlined in SDDOT Performance Standard Function 2125, Portland Cement Concrete Surface Repair.

In general, SDDOT Function 2125 requires that holes be drilled into the exposed faces of the existing PCC on 305-mm (12-in) centers, and No. 5 bars should be epoxied into the holes. Please note that tie bars should not be provided across existing transverse contraction joints. These joints are "working" joints, and their movement cannot be restricted by a tie bar. Load transfer can be provided at transverse contraction joints by smooth dowel bars.

6.2.4. *Diamond Grinding*

Diamond grinding consists of the removal of hardened concrete through the use of closely spaced diamond saw blades. The major purpose of diamond grinding is to correct surface irregularities (e.g., joint faulting) or to remove a polished surface.

6.2.5. *AC Overlays*

AC overlays can be placed on an existing PCC pavement to correct (cover) existing surface deficiencies and to provide additional pavement structure. If properly designed and constructed, structural AC overlays (100 mm [4.0 in] thick, or greater) can significantly extend the service life of an existing PCC pavement.

One of the major concerns with AC overlays placed on a concrete pavement is reflection cracking. Reflection cracking is the development of cracks in the overlay caused by horizontal and vertical movements of cracks and joints in the underlying existing pavement. This form of cracking causes early overlay deterioration, increased pavement maintenance costs, and reduced service life of the overlay. Several methods for controlling and minimizing reflection cracking are available, including sawing and sealing of the AC overlay above the joints and cracks and the use of stress-relieving interlayers.

6.2.6 *Crack and Seat or Break and Seat Followed by an AC Overlay*

Crack and seat consists of cracking the PCC slab into small segments, seating the segments with heavy rollers to eliminate underlying voids, and overlaying the segments with AC. The term *crack and seat* is generally used for JPCP, and the term *break and seat* is typically used when the existing pavement is JRCP. In break and seat, either the steel must be ruptured or the bond between the steel and PCC must be broken.

The overall intent of the crack and seat procedure is to break the slab into small segments so that thermal movements of the PCC are minimal, thereby reducing reflection cracking in the AC overlay. Typically, the PCC segments are 0.4 to 0.6 m² (4 to 6 ft²) in size. Although, the PCC slab is broken into smaller pieces, the pieces are

large enough to maintain much of the slabs original structural integrity due to the aggregate interlock between the pieces.

6.2.7. New or Reconstructed JPCP

JPCP typically ranges in thickness from 150 to 250 mm (6.0 to 10.0 in) for most rural road applications. In areas of high truck traffic and exceptionally weak subgrade conditions, a thicker section may be required. The minimum JPCP thickness that the SDDOT will use is 8.0 in.

Bases: The use of a granular base beneath all PCC pavements is strongly encouraged. The primary function of a base in a JPCP system is to provide uniform, non-erodible support for the overlying pavement. The strength of the base layer (and subgrade) has minimal impact on the load-related stresses occurring in the JPCP slab. Without a base, the subgrade can pump or erode, and nonuniform support (or no support, in some locations) may occur and cause joint faulting or slab cracking. Therefore, a 100-mm (4.0-in) thick, dense-graded aggregate base layer is recommended beneath all JPCP. The aggregate material should comply with section 882, Aggregates for Granular Bases and Surfacing, of the SDDOT Standard Specifications for Road and Bridge Construction.

Suggested JPCP Thicknesses: The necessary JPCP thickness for a given rural road will depend on the anticipated traffic levels (especially heavy trucks), the subgrade support conditions, the desired design life, and the type of load transfer at the transverse contraction joints. As noted above, the minimum JPCP thickness used by the SDDOT is 8.0 in. Because of the shortened life of under-designed concrete pavements and their costly rehabilitation, extreme caution should be used when selecting concrete thicknesses less than 200 mm (8.0 in).

The recommended minimum JPCP thicknesses for rural roads in South Dakota are presented in Table 6.1. The thicknesses presented in Table 6.1 were calculated using the current AASHTO pavement design procedures and are based on a 40-year design life, a design reliability level of 75 percent, and a truck traffic level of less than 200 trucks per day. The PCC was estimated to have an average 28-day modulus of rupture (flexural strength) of 650 psi. These thicknesses are also based on the use of a granular subbase beneath the JPCP slabs. A 200-mm (8.0-in) minimum PCC thickness is recommended.

The thicknesses presented in Table 6.1 are intended to serve as guidelines. Consultation with the SDDOT Office of Local Government Assistance (605-773-4831) regarding is strongly suggested prior to the selection of a PCC pavement design thickness.

Table 6.1. Summary of recommended JPCP thicknesses.

Road classification and estimated daily truck traffic	Minimum aggregate base thickness (in)	Minimum PCC thickness (in) ^a
Light truck traffic (0 to 15 heavy trucks per day in design lane)	4.0	8.0 ^b
Medium truck traffic (15 to 50 heavy trucks per day in design lane)	4.0	8.0 ^b
Heavy truck traffic (50 to 200 heavy trucks per day in design lane)	4.0	9.5

Notes: ^aDowel bars are recommended at the transverse joints.

^bRecommended minimum thickness.

Construction inspection: Guidelines for the construction of concrete pavement are detailed in section 380, Portland Cement Concrete Pavement, of the SDDOT Standard Specifications for Road and Bridge Construction. A summary of many of the SDDOT requirements is provided below.

When constructing a concrete pavement, the SDDOT-approved PCC mixtures should be used. This ensures that the material is a high-quality, tested mixture and minimizes the potential of future material durability-related pavement problems.

PCC pavement construction should be performed only when the placement temperature of the PCC is between 10 and 32°C (50 and 90°F). Also, the in-place PCC temperature should be above 0°C (32°F) until the PCC has attained a compressive strength of at least 10.3 MPa (1,500 psi).

The major parameters of the PCC mixture that should be inspected or tested are the aggregate gradation, mixture consistency, entrained air content, and strength. The gradation of the aggregates is performed using a sieve analysis on samples obtained from either the aggregate hoppers or stock piles. The mixture consistency is typically measured using a PCC slump cone. The slump of a PCC mixture should be between 25 and 75 mm (1.0 and 3.0 in) for fixed-form construction and should be no more than 50 mm (2.0 in) for slip-form construction. Air-entrainment is necessary to accommodate freeze-thaw cycles within the PCC, and the amount of entrained air in a PCC mixture should be between 4.0 and 7.0 percent of the volume of the mixture. The entrained air content in fresh concrete can be measured with one of several available types of PCC air

meters. PCC strength can be measured through compressive strength, flexural strength, or indirect-tensile strength tests on hardened PCC samples. Compressive and flexural strength tests are typically performed. In general, the PCC should have a 28-day compressive strength of at least 24 MPa (3,500 psi) or a 28-day flexural strength of 4.5 MPa (650 psi).

6.3. Jointed Plain Concrete Pavement Joints

Joint layout and type are important parameters that significantly affect the performance of JPCP. Improper joint layout and design can result in premature (sometimes almost immediate) cracking in JPCP. Excessively long joint spacing, improper intersection layout, and improper joint formation (i.e., improper or late sawing) are some of the primary culprits in joint-related JPCP cracking.

6.3.1. Longitudinal Joint Spacing

In wide JPCP slabs that are relatively thin (e.g., city streets), excessively high stresses occur in the wheel paths at the transverse joints. These load-induced stresses are further magnified by the warping and curling of the slab corners as a result of vertical temperature and moisture gradients within the slab. These high stresses can cause a longitudinal crack to initiate at the transverse joint; subsequent vehicle loadings can cause the crack to propagate longitudinally across the entire length of the slab.

To minimize the amount of longitudinal cracking, the maximum longitudinal joint spacing should not exceed 3.65 m (12 ft). In addition to staying within the maximum joint spacing limits, the longitudinal joints should be located away from the wheel path locations (preferably at lane lines) as much as possible in order to minimize the number of traffic loadings occurring at the joint. Traffic loadings can create excessively high stresses at the longitudinal joint, resulting in transverse slab cracking.

6.3.2. Transverse Joint Spacing

The occurrence of transverse cracking in PCC slabs is highly correlated to the transverse joint spacing, with transverse cracking decreasing as transverse joint spacing is reduced. Excessively high curling and warping stresses can occur at the longitudinal joint in JPCP with long transverse joint spacings (greater than 6.1 m [20 ft]). The magnitude of these stresses can be significantly reduced with a decreased transverse joint spacing. Therefore, the maximum transverse joint spacing should not exceed 6.1 m (20 ft). The use of a 6.1-m (20-ft) transverse joint spacing will minimize the amount of movement occurring at the transverse joints as a result of thermal expansion and contraction. In addition, the transverse joints should be doweled using 1 1/4 in, epoxy coated dowels on 12.0-in centers (see Plate 380.01 of the SDDOT details in Appendix A).

6.3.3. Joint Design

Detail drawings of the SDDOT-recommended joint layout and design are provided in Appendix A.

7. SUBGRADE SOILS

7.1. Design Considerations

Subgrade support (strength) is an important input in almost any pavement design procedure. For the proper design of AC, PCC, blotter, or gravel roads, it is necessary to assess the existing subgrade support conditions. Underestimating the subgrade support conditions can result in overdesigned pavements. Even worse, the overestimation of subgrade support conditions can result in premature pavement failure.

Subgrade support can be represented by several parameters, including the California Bearing Ratio (CBR), the modulus of subgrade reaction (k), and the resilient modulus. The CBR has traditionally been the required design input for flexible pavement designs, and the k-value has traditionally been the required input for PCC pavement designs. The resilient modulus has recently gained acceptance in the pavement design area, and it is currently used in many flexible design procedures. An approximate relationship between CBR, k-value, and other soil parameters is published by the Portland Cement Association (PCA 1994) and is illustrated in Figure 7.1.

The *AASHTO Guide for Design of Pavement Structures* (AASHTO 1993) indicates that the resilient modulus (in psi) of many fine-grained soils is roughly 1,500 times the soil's CBR value. The AASHTO Design Guide also indicates that the resilient modulus (in psi) of many soils is approximately 19 times the k-value (in pci) of the soil.

In many instances, and especially in local road applications, accurate determination of soil strength parameters through extensive laboratory or field testing is neither practical nor feasible. However, for these situations there are ways in which the subgrade support conditions can quickly and inexpensively be estimated. These methods include the use of published correlations between a soil's liquid limit and its CBR, and the use of expedient indicator tests, such as the dynamic cone penetrometer (DCP).

In the first method, the SDDOT-established relationships between liquid limit and CBR are utilized. These relationships are based on experience and are presented in Table 7.1. The liquid limit of a soil is an easy and relatively inexpensive laboratory test to perform. Another method of estimating the liquid limit and CBR values of a given soil is through the use of a county soils report. Information about the near-surface (subgrade) soil types (and soil properties) located within the project limits can be easily obtained from a county soils report. County soils reports are published by the United States Department of Agriculture, Soil Conservation Service (SCS). These reports exist for many of the counties in South Dakota and are typically available, free of charge, at the local SCS office.

SUBGRADE SOILS

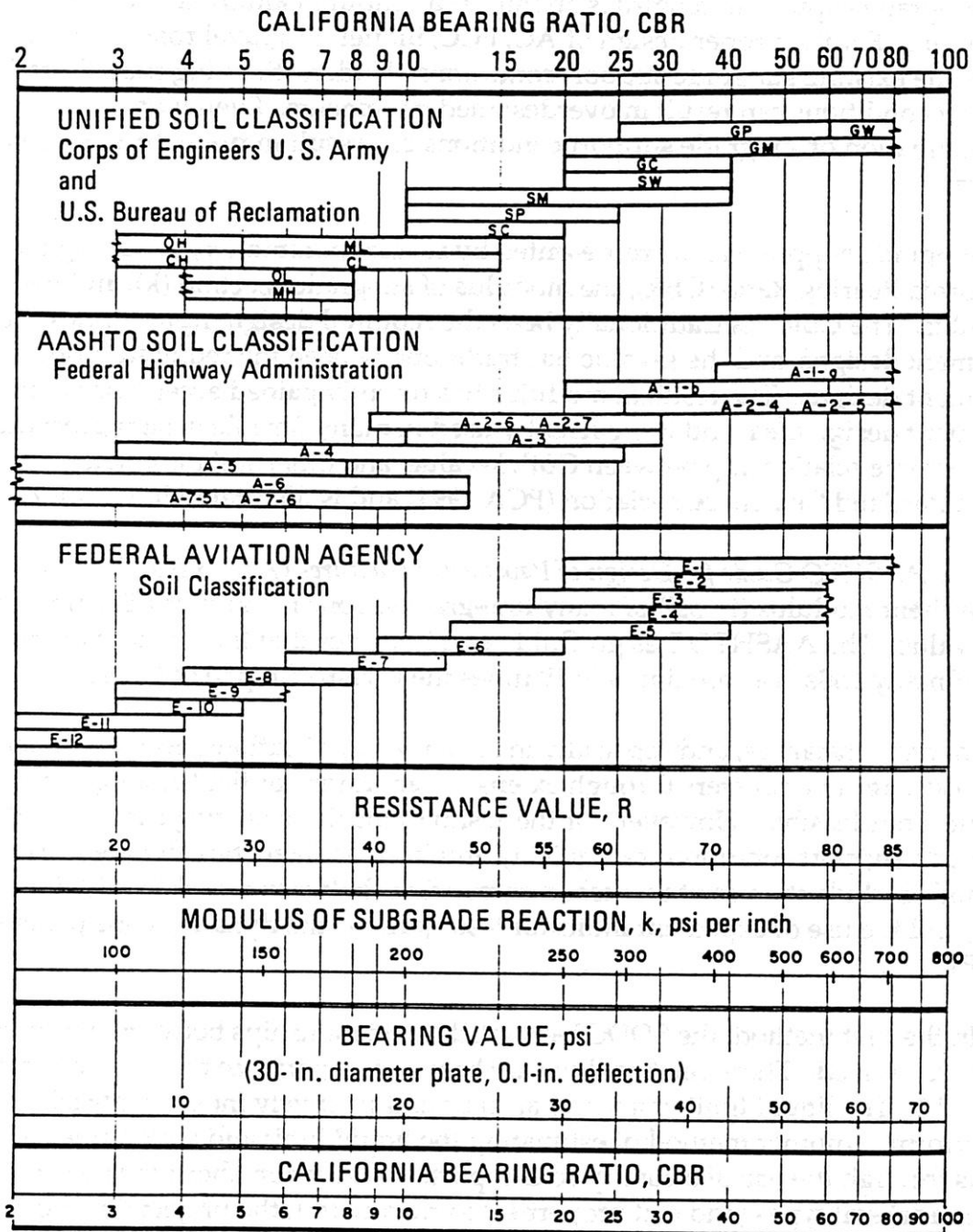

Figure 7.1. Approximate relationship of soil parameters (PCA 1984).

Table 7.1. Summary of relationship between liquid limit and CBR of typical South Dakota soils.

Liquid Limit, %	Approximate CBR, %
0 to 30	> 8.5
30 to 40	5.0 to 8.5
40 to 50	3.3 to 5.0
50 to 75	1.5 to 3.3
> 75	< 1.5

The second method for estimating CBR values is to utilize an expedient test procedure such as the DCP. The DCP consists of a cone-tipped rod that is continuously driven into the subgrade soil by dropping an 8-kg (17.6-lb) weight a specified height. The DCP can be extended approximately 1.2 m (4 ft) into the subgrade, and for fine-grained soils the test typically takes less than 5 minutes to complete. An illustration of the DCP is provided in Figure 7.2.

To determine the approximate CBR of a soil, the DCP is driven into the soil as discussed above. The cone penetration rate is then measured, and the corresponding CBR is determined using the relationship presented in Figure 7.3.

7.2. Construction Considerations

Proper compaction of subgrade soils is imperative to ensure good pavement performance. Improperly prepared subgrade soils have a much greater tendency to pump, erode, or permanently deform (rut) than soils that are properly compacted.

Guidelines on the proper techniques for preparing subgrade soils are provided in Section 120, Roadway and Drainage Excavation and Embankment Construction, of the SDDOT Standard Specifications for Road and Bridge Construction. In general, the specifications require that all subgrade soils be compacted to at least 95 percent of maximum dry density as determined by SDDOT standard test procedure SD 104 (standard Proctor test), at no lower than 4 percentage points below optimum moisture. When gravelly soils are encountered, the density requirements should be used, but the moisture content should be as needed to obtain density. All topsoil material should be removed from the subgrade.

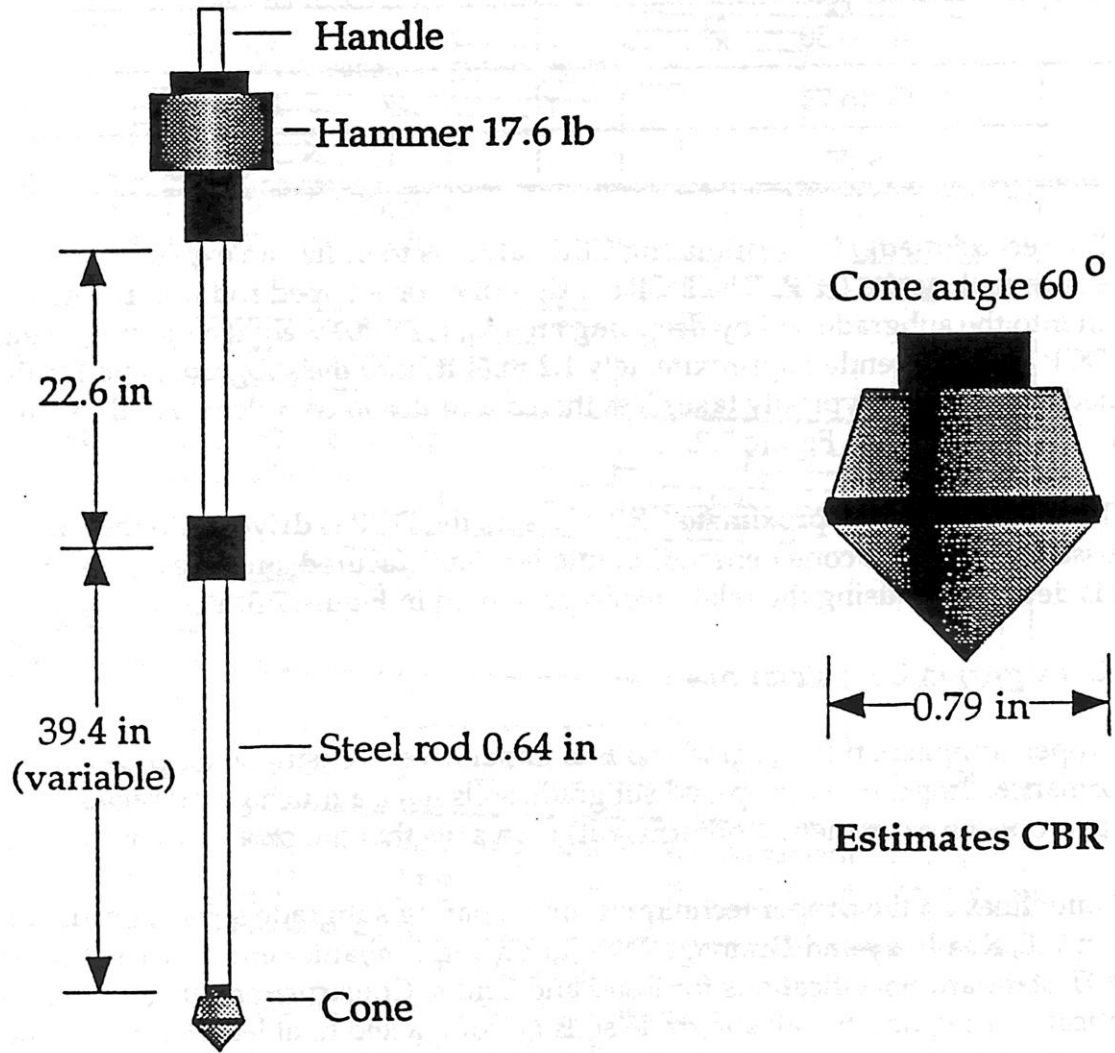

Figure 7.2. Illustration of dynamic cone penetrometer (DCP).

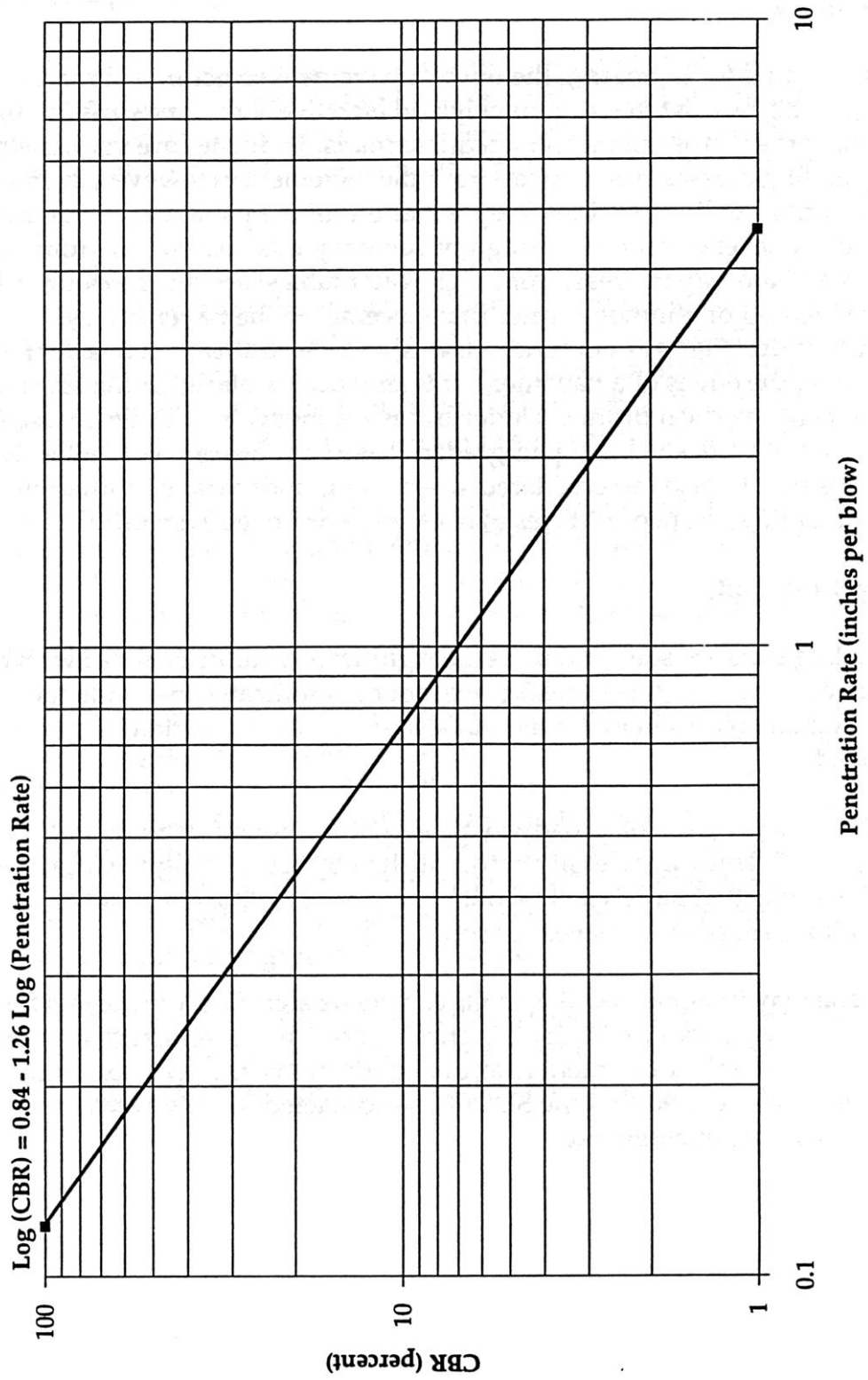

Figure 7.3. Relationship between DCP penetration rate and CBR.

7.3. Drainage

One method for increasing the life of a pavement structure is to make sure that drainage patterns exist that can quickly and effectively remove surface moisture. Proper pavement cross slope and adequate roadside ditches are very effective in quickly getting surface runoff away from the pavement. However, even good surface runoff drainage will not entirely keep water out of the pavement. Water can enter the pavement by several routes – through pavement joints and cracks, from adjacent grassed and landscaped areas, from high water tables, and via moisture vapor. An effective method of removing water that has entered the pavement system is the use of a subsurface drainage system (underdrains). Underdrains can consist of longitudinal drains along the edges of a pavement or lateral drains placed at the low points along the pavement's vertical profile. Underdrains are most effective when used in association with a drainable (open-graded) base or subbase layer. Filter layers or geotextiles should also be considered when using underdrains. Otherwise, the migration of fine-grained particles may clog the drainage system.

7.4. Swelling Soils

Swelling soils are soils that undergo significant volume changes with changes in moisture content. The term *swelling soils* not only indicates the tendency to increase in volume with increases in moisture, but also indicates the tendency to shrink if moisture is removed.

In the development of a roadway project, it is imperative to identify the presence of swelling soils. This can be easily accomplished by referencing the local county soils report. All soils that have a soil taxonomy order of *vertisol* (i.e., contain *ert* in the soil classification) are potential swelling soils.

As one may imagine, swelling soils can create significant problems for pavement structures. If a highly swelling soil is encountered, it is essential that the soil be compacted at a moisture content near or slightly above the optimum moisture content. Also, it is recommended that the SDDOT be contacted for advice when swelling subgrade soils are encountered.

8. TRENCH BACKFILLING

Trench settlement can occur when trenches are improperly backfilled. This settlement results in voids and nonuniform support conditions beneath the pavement structure, causing differential pavement settlement and pavement cracking. Therefore, it is imperative that all trenches located beneath a pavement structure be properly backfilled.

Current backfilling practices commonly include either the jetting of fine-aggregate material (sand) or the mechanical compaction of soil or aggregate. Unfortunately, especially in local road construction, the jetting of sand is better described as the inundation or flooding of sand, and mechanical compaction all too often includes placement of thick, loosely compacted lifts of backfill material. Both of these techniques are unacceptable and typically result in subsequent trench settlement.

To minimize the number and severity of trench settlements, the backfilling of trenches with controlled low-strength material (CLSM) or thin lifts (100 mm [4 in] maximum) of mechanically compacted fine-aggregate backfill material is recommended. Either method is acceptable, and allowing either of these alternatives provides flexibility to contractors.

CLSM (also known as flowable fill) is a mixture of portland cement, fly ash, fine aggregate, and water proportioned to provide a backfill material that is self-compacting, self-leveling, and capable of being excavated with hand tools, if necessary, at a later date. CLSM can be produced at most ready-mix concrete operations and is generally discharged directly from a ready-mix concrete truck. Although the material cost of CLSM is higher than that of conventional backfill materials, the combined material and labor costs for CLSM are generally comparable to (or cheaper than) the total cost of properly placed aggregate backfill material.

For both the CLSM and the granular backfill methods, the top 305 mm (12 in) of the trench should be filled with soil of similar composition to that of the adjacent subgrade. Placement of the 305-mm (12-in) thick layer will promote uniformity in subgrade support.

9. REFERENCES

American Association of State Highway and Transportation Officials (AASHTO), 1990, *A Policy on Geometric Design of Highway and Streets*, Washington, DC.

American Association of State Highway and Transportation Officials (AASHTO), 1993, *AASHTO Guide for Design of Pavement Structures – Volume I*, Washington, DC.

American Concrete Pavement Association, 1993, *Joint and Crack Sealing and Repair for Concrete Pavements*, Technical Bulletin – 012.0, Skokie, IL.

Asphalt Institute, 1983, *Principles of Construction of Hot-Mix Asphalt Pavements*, Manual Series No. 22, College Park, MD.

Eaton, R.A. and R.E. Beaucham, December 1989, *Unsurfaced Road Maintenance Management*, United States Army Corps of Engineers, Cold Regions Research and Engineering Laboratory, Hanover, NH.

ERES Consultants, Inc., 1993, *Techniques for Pavement Rehabilitation*, 5th Edition, Federal Highway Administration, Washington, DC.

Portland Cement Association, 1992, *Design and Construction of Joints for Concrete Streets*, IS061.01P, Skokie, IL.

Portland Cement Association, 1984, *Thickness Design for Concrete Highway and Street Pavements*, Skokie, IL.

Roberts, F.L., P.S. Kandhal, E.R. Brown, D. Lee, and T.W. Kennedy, 1991, *Hot Mix Asphalt Materials, Mixture Design, and Construction*, National Center for Asphalt Technology, NAPA Education Foundation, Lanham, MD.

South Dakota Department of Transportation, 1990, *Standard Specifications for Roads and Bridges*, Pierre, SD.

South Dakota Department of Transportation, Performance Standard, Function 2101, October 1992, *Patching with Premix*, Pierre, SD.

South Dakota Department of Transportation, Performance Standard, Function 2107, October 1992, *Seal Coating*, Pierre, SD.

South Dakota Department of Transportation, Performance Standard, Function 2111, December 1993, *Crack Treating*, Pierre, SD.

South Dakota Department of Transportation, Performance Standard, Function 2112, December 1993, *Rout & Seal Cracks*, Pierre, SD.

REFERENCES

South Dakota Department of Transportation, Performance Standard, Function 2125, October 1992, *Portland Cement Concrete Surface Repair*, Pierre, SD.

South Dakota Department of Transportation, Performance Standard, Function 2135, October 1992, *Sealing Transverse Contraction Joints, Longitudinal Joints, and Cracks in PCCP with Silicone*, Pierre, SD.

ERES Consultants, Inc., 1993, *Innovative Materials Development and Testing – Volumes I through V*, SHRP-H-352, SHRP-H-353, SHRP-H-354, SHRP-H-355, and SHRP-H-356, Washington, DC.

Transportation Information Center, University of Wisconsin-Madison, May 1989, *Asphalt – PASER Manual, Pavement Surface Evaluation and Rating*, Madison, WI.

Transportation Information Center, University of Wisconsin-Madison, May 1989, *Concrete – PASER Manual, Pavement Surface Evaluation and Rating*, Madison, WI.

Transportation Information Center, University of Wisconsin-Madison, May 1989, *Gravel – PASER Manual, Pavement Surface Evaluation and Rating*, Madison, WI.

APPENDIX A

APPENDIX A – SDDOT JPCP JOINT DETAILS

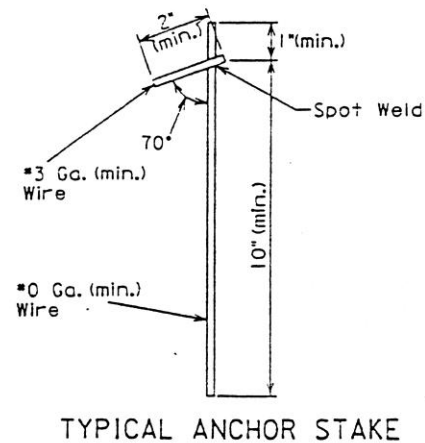
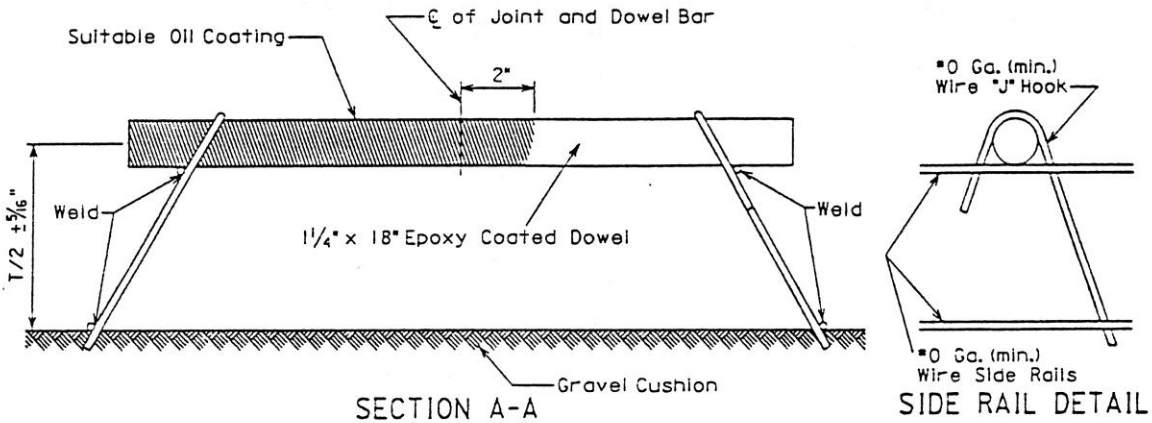
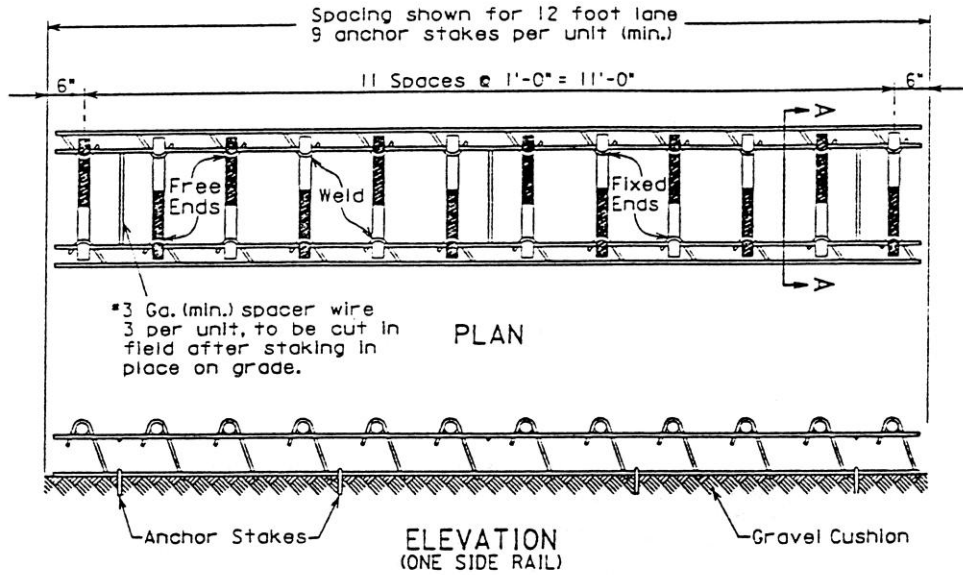

GENERAL NOTES:

Centerline of individual dowel bars shall be parallel to top of subgrade $\pm 1/8$ inch in 18 inches and to all other dowel bars in the assembly $\pm 1/16$ inch in 18 inches.

Centerline of individual dowel bars shall be parallel to the centerline of the roadway $\pm 1/2$ inch in 18 inches.

The transverse contraction joints shall be sawed perpendicular to the centerline of the roadway and the dowel bars shall be centered on the sawed joint ± 1 inch.

Supporting devices of the type shown on this sheet, or equivalent as approved by the Engineer, are to be used to maintain proper horizontal and vertical alignment of the dowel bars.

Linear foot measurement for dowel bar assemblies shall be based on one foot of length for each dowel bar in the assembly.

October 9, 1990

SPECIFICATION REFERENCE NO. 380	STATE OF SOUTH DAKOTA DEPARTMENT OF TRANSPORTATION PCC PAVEMENT DOWEL BAR ASSEMBLY FOR TRANSVERSE CONTRACTION JOINTS	PLATE NUMBER 380.01
--	---	---------------------------

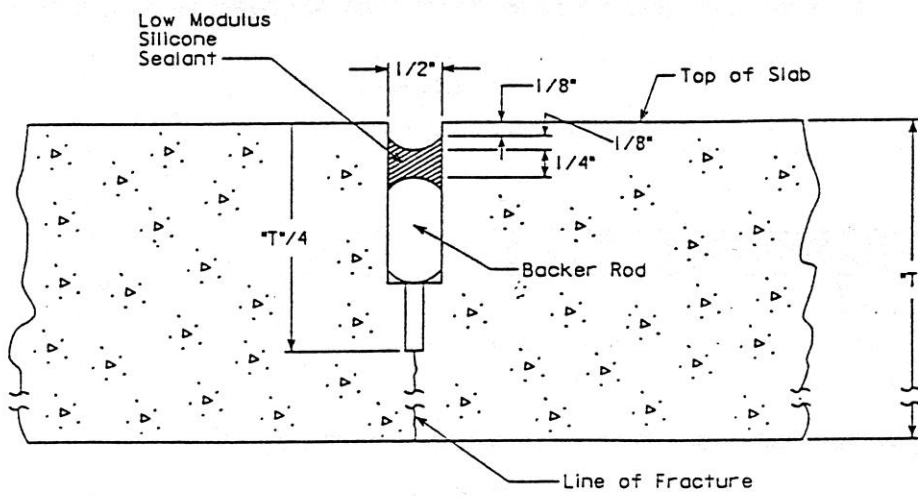

T = Pavement Thickness

GENERAL NOTES:

The first saw cut to control cracking shall be a minimum of 1/4 the depth of the pavement. Additional sawing for widening the saw cut to provide the width for the installation of the Low Modulus Silicone Joint Sealant will be necessary.

Backer Rod shall be of non-moisture absorbing resilient material approximately 25% larger in diameter than the width of the joint to be sealed.

June 22, 1990

SPECIFICATION
REFERENCE
NO.
380

STATE OF SOUTH DAKOTA
DEPARTMENT OF TRANSPORTATION
PCC PAVEMENT TRANSVERSE CONTRACTION
JOINT W/WITHOUT DOWEL BAR ASSEMBLY

PLATE
NUMBER
380.02

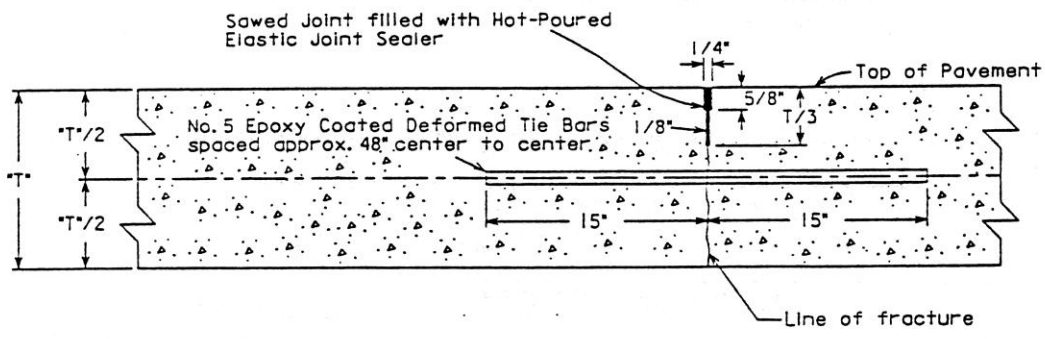

T = Pavement Thickness

GENERAL NOTE:

The first saw cut to control cracking shall be a minimum of 1/3 the depth of the pavement. Additional sawing for widening the saw cut to provide the width for the installation of the Hot-Poured Elastic Joint Sealer will be necessary.

April 30, 1991

SPECIFICATION REFERENCE NO. 380	STATE OF SOUTH DAKOTA DEPARTMENT OF TRANSPORTATION PCC PAVEMENT SAWED LONGITUDINAL JOINT	PLATE NUMBER 380.03
--	---	---------------------------

FORMED PAVEMENT

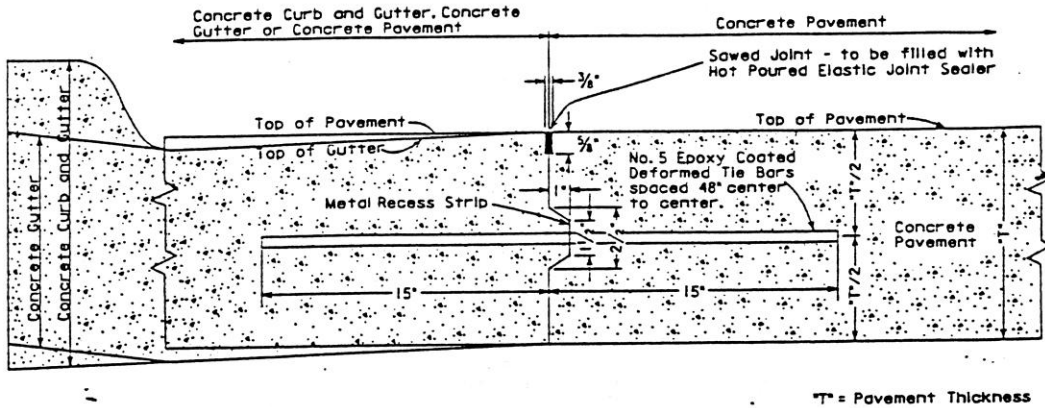

GENERAL NOTE:

If proposed, approval of alternate designs of Metal Recess Strips will be considered by the Engineer.

SLIPFORMED PAVEMENT

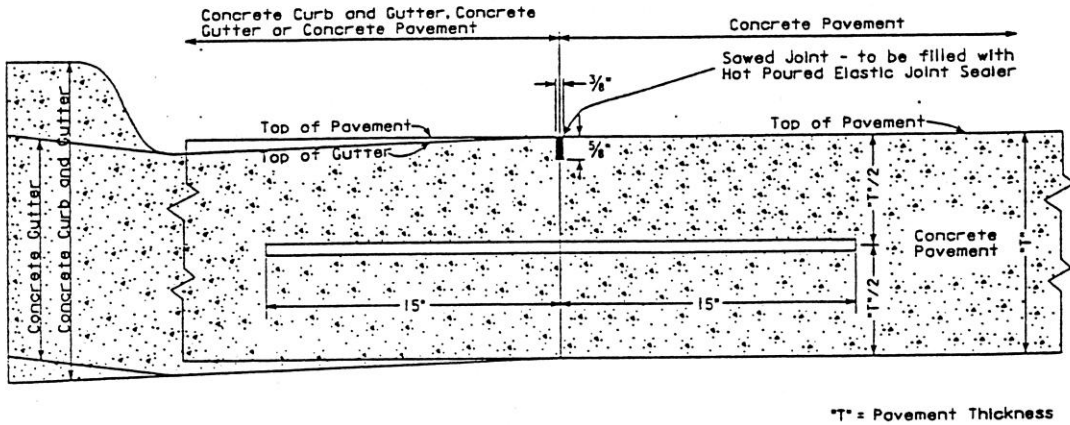

GENERAL NOTES:

No. 5 epoxy coated deformed tie bars spaced approximately 48" center to center with concrete curb and gutter and spaced approximately 30" center to center with concrete pavement.

The mainline curb and gutter may be poured monolithically with the portland cement concrete pavement. If this method of construction is used the tie bars and the saw joint between the curb and gutter and the p.c.c. pavement shall be eliminated. The curb and gutter shall be sawed transversely at each mainline transverse contraction joint. The transverse contraction joints in the curb and gutter shall be sawed and sealed the same as for the transverse contraction joints in the p.c.c. pavement. The slope of the gutter shall be the slope designated for the type of curb and gutter or gutter to be constructed. The bottom slope of the curb and gutter or gutter section shall be constructed to the slope of the mainline concrete pavement.

April 25, 1991

<p>SPECIFICATION REFERENCE</p> <p>NO. 380</p>	<p>STATE OF SOUTH DAKOTA</p> <p>DEPARTMENT OF TRANSPORTATION</p> <p>PCCP LONGITUDINAL CONSTRUCTION JOINT WITH TIE BARS WITH OR WITHOUT CURB & GUTTER</p>	<p>PLATE NUMBER</p> <p>380.04</p>
---	--	-----------------------------------

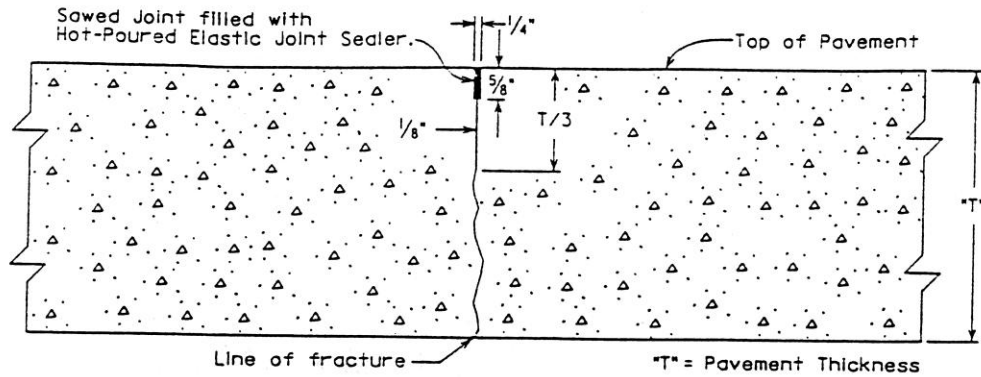

GENERAL NOTES:

The first saw cut to control cracking shall be a minimum of 1/3 the depth of the pavement. Additional sawing for widening the saw cut to provide the width for the installation of the Hot-Poured Elastic Joint Sealer will be necessary.

Where permitted by the Engineer, the longitudinal joint shown above may be substituted for the longitudinal construction joint with a keyway.

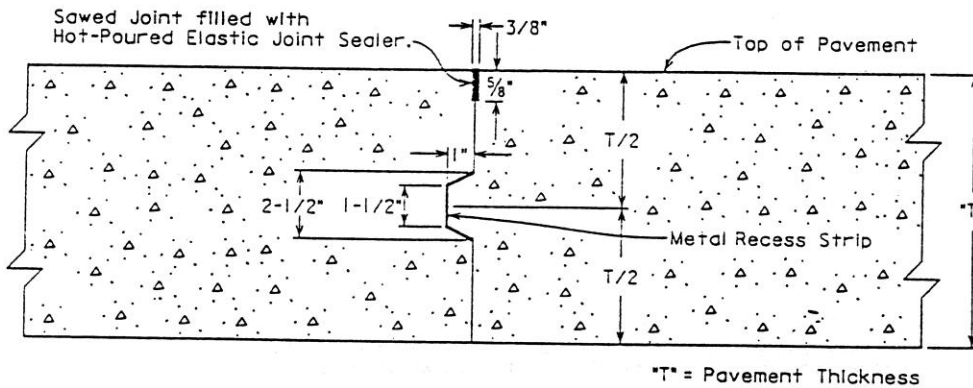

GENERAL NOTE:

If proposed, approval of alternate designs of the Metal Recess Strip will be considered by the Engineer.

SPECIFICATION REFERENCE NO. 380	April 16, 1991	
	STATE OF SOUTH DAKOTA DEPARTMENT OF TRANSPORTATION PCC PAVEMENT LONGITUDINAL CONSTRUCTION JOINT WITHOUT TIE BARS	PLATE NUMBER 380.05

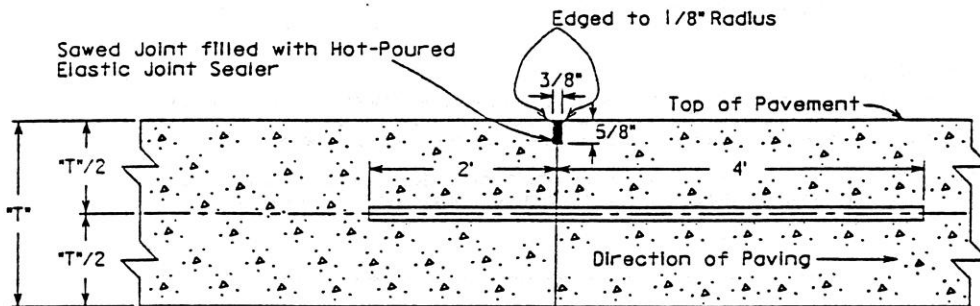

T* = Pavement Thickness

GENERAL NOTES:

No. 4 epoxy coated deformed tie bars shall be spaced 12" center to center and approximately 6" from the pavement edges.

When a transverse construction joint is made, no paving will be done in this area for 12 hours.

The distance between a transverse construction joint with tie bars and an adjacent transverse contraction joint shall be 9 to 10 feet.

April 18, 1991

SPECIFICATION REFERENCE NO. 380	STATE OF SOUTH DAKOTA DEPARTMENT OF TRANSPORTATION PCC PAVEMENT TRANSVERSE CONSTRUCTION JOINT WITH TIE BARS	PLATE NUMBER 380.06
--	--	---------------------------

Sawed Joint to be filled with Hot-Poured Elastic Joint Sealer or other Sealer as approved by the Engineer.

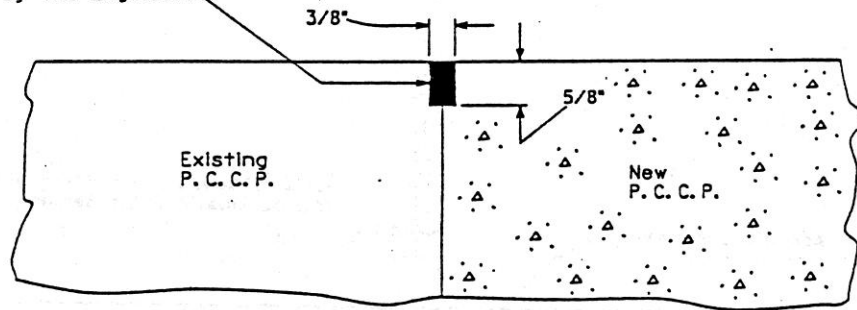

June 22, 1990

<p>SPECIFICATION REFERENCE NO. 380</p>	<p>STATE OF SOUTH DAKOTA DEPARTMENT OF TRANSPORTATION PCC PAYEMENT CONSTRUCTION JOINT ADJACENT TO EXISTING PAYEMENT</p>	<p>PLATE NUMBER 380.07</p>
--	---	------------------------------------

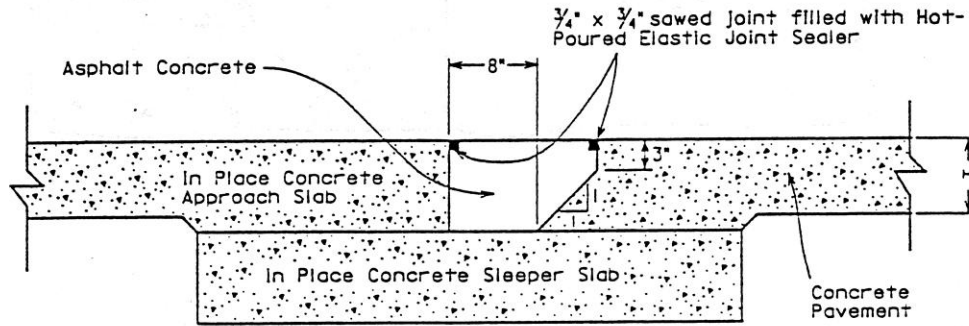
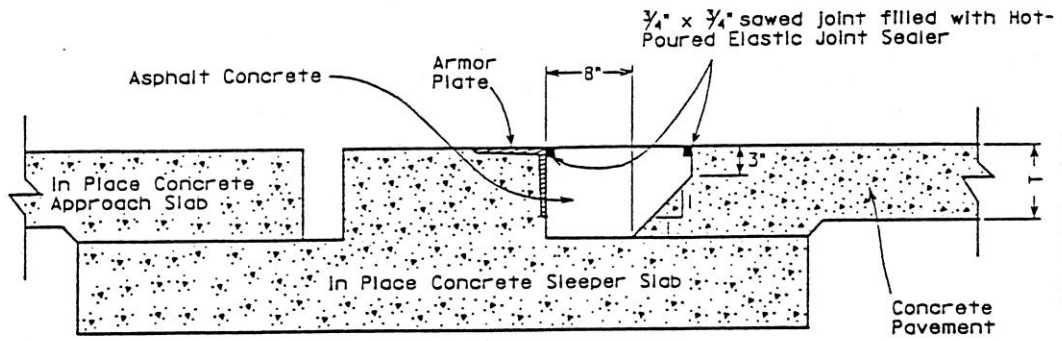

T = Pavement Thickness

July 1, 1993

SPECIFICATION REFERENCE NO. 380	STATE OF SOUTH DAKOTA DEPARTMENT OF TRANSPORTATION PCC PAVEMENT GROWTH JOINTS	PLATE NUMBER 380.08
--	---	---------------------------

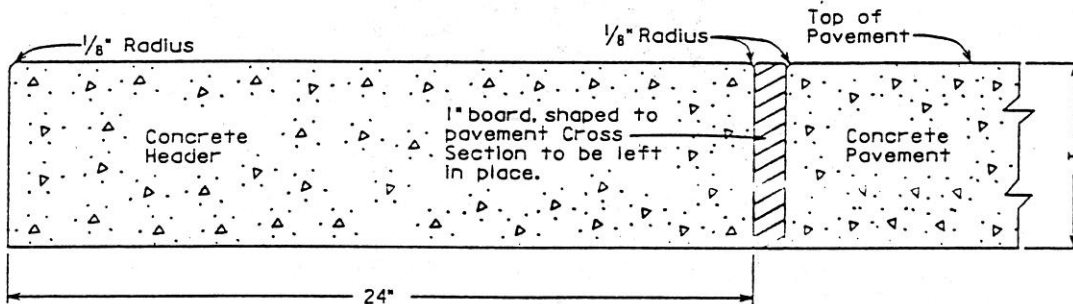

T = Pavement Thickness

GENERAL NOTES:

Concrete Headers shall be constructed ordinarily at the Beginnings and Ends of Projects and/or at such points as are designated by the Engineer.

The cost of furnishing and installing the 1" board shall be absorbed and included in the contract unit price per square yard for "Concrete Headers."

May 8, 1991

SPECIFICATION REFERENCE NO. 380	STATE OF SOUTH DAKOTA DEPARTMENT OF TRANSPORTATION PCC PAVEMENT CONCRETE HEADER	PLATE NUMBER 380.09
--	---	---------------------------

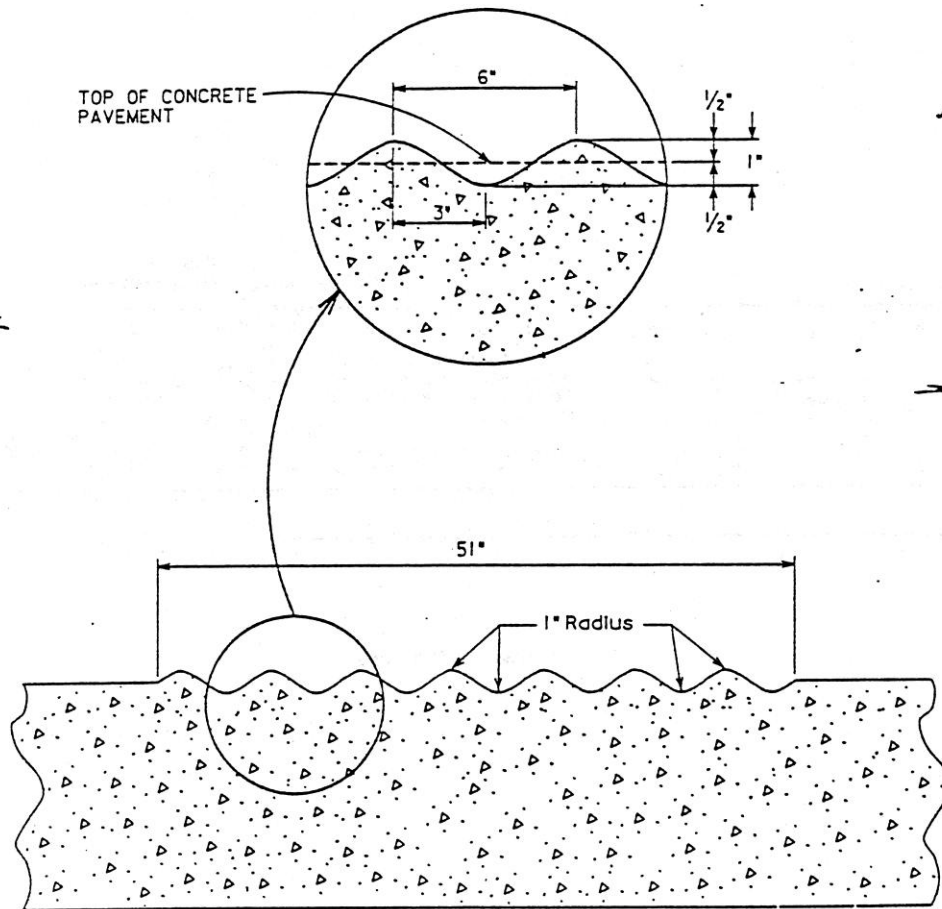

GENERAL NOTE:

Rumble Strips shall be spaced 60 feet Center to Center and shall not coincide with any transverse contraction joints.

June 24, 1931

SPECIFICATION REFERENCE NO. 380	STATE OF SOUTH DAKOTA DEPARTMENT OF TRANSPORTATION PCC PAVEMENT RUMBLE STRIP	PLATE NUMBER 380.10
--	--	---------------------------

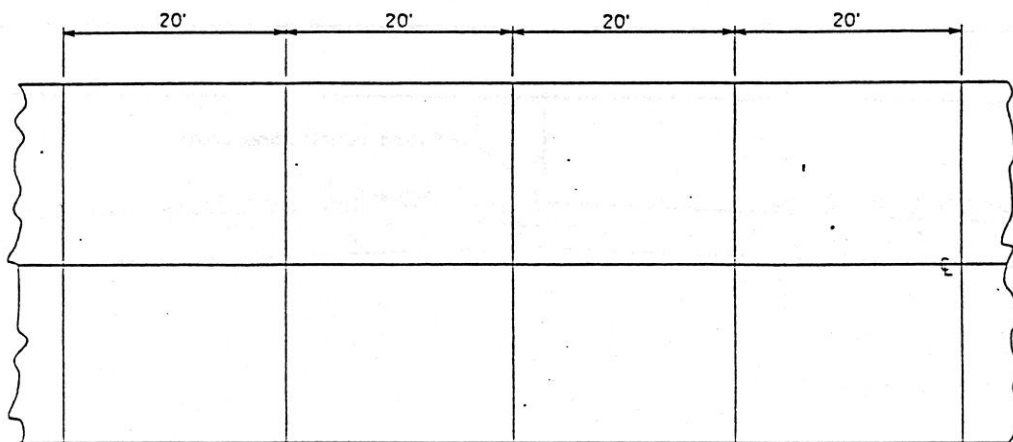

June 25, 1990

SPECIFICATION REFERENCE NO. 380	STATE OF SOUTH DAKOTA DEPARTMENT OF TRANSPORTATION PCC PAVEMENT TYPICAL CONTRACTION JOINT SPACING	PLATE NUMBER 380.11
--	--	---------------------------

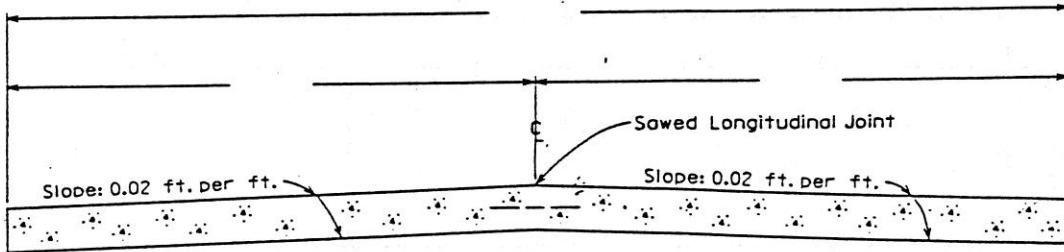

May 22, 1990

SPECIFICATION REFERENCE NO. 380	STATE OF SOUTH DAKOTA DEPARTMENT OF TRANSPORTATION PCC PAVEMENT TRANSVERSE SECTION	PLATE NUMBER 380.12
--	--	---------------------------

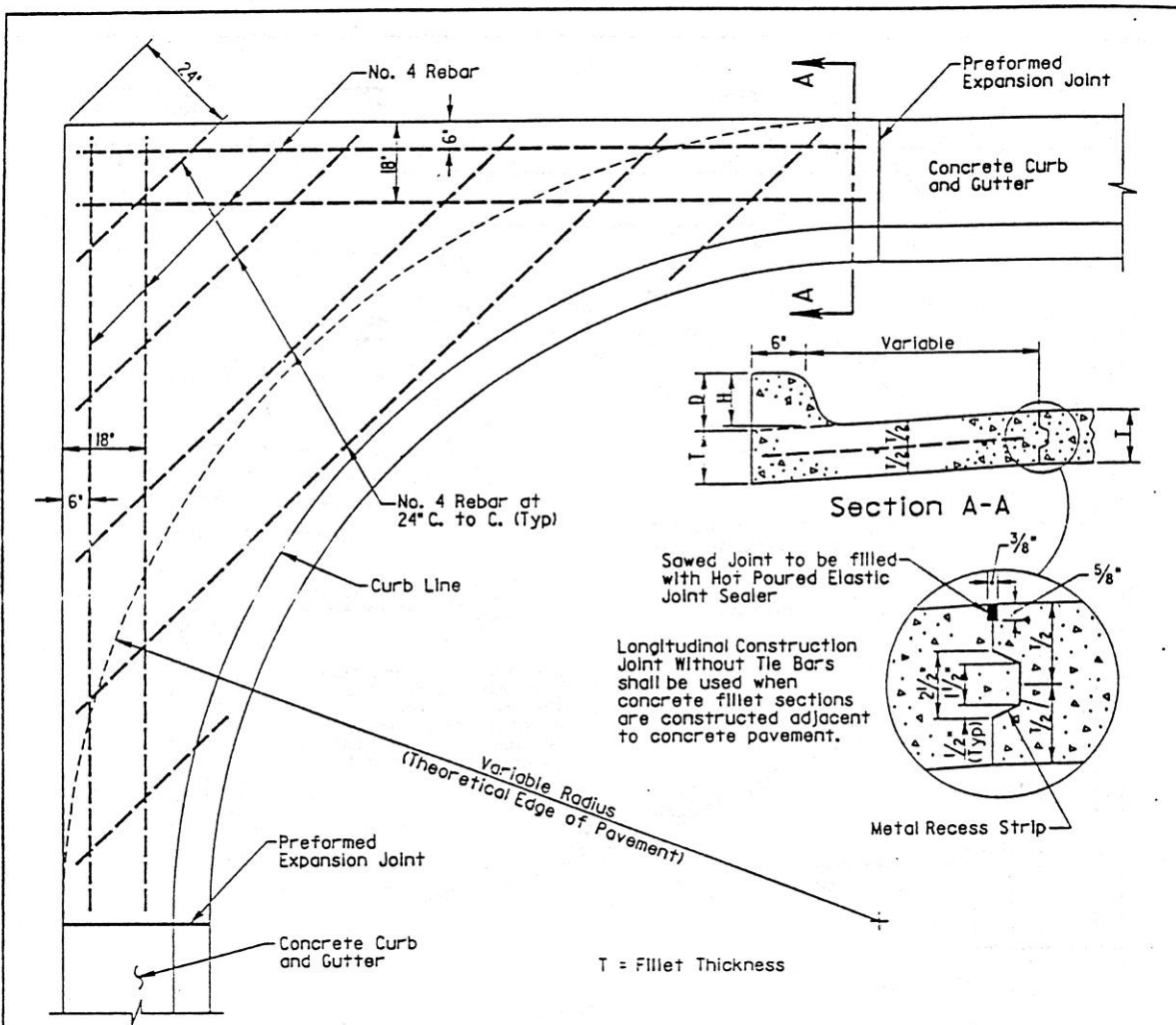

GENERAL NOTES:

Dimensions "D", "H", and "T" shall conform to those shown on the appropriate Curb and Gutter Standard.

All rebars shall be epoxy coated and shall conform to A.S.T.M. A615 Grade 60 and the South Dakota Standard Specifications for Roads and Bridges, Section 480 and 1010. All rebars shall have a minimum of 3" cover.

Class M-6 Concrete shall be used in construction of the fillets.

The concrete curb shall be monolithic with the concrete fillet. No separate payment for this curb will be made, same being considered a part of the fillet.

Joints shall be constructed at 10' intervals except when fillets are constructed adjacent to PCC Pavement then the joints shall be extended from edge of pavement through the fillet section as directed by the Engineer.

The cost of all materials, labor and incidentals necessary to complete the same shall be included and absorbed in the contract unit price per Square Yard for Concrete Fillet Section.

July 1, 1992

SPECIFICATION REFERENCE NO. 380	STATE OF SOUTH DAKOTA DEPARTMENT OF TRANSPORTATION PCC FILLET SECTION WITH TYPE B CURB & GUTTER	PLATE NUMBER 380.13
--	--	---------------------------

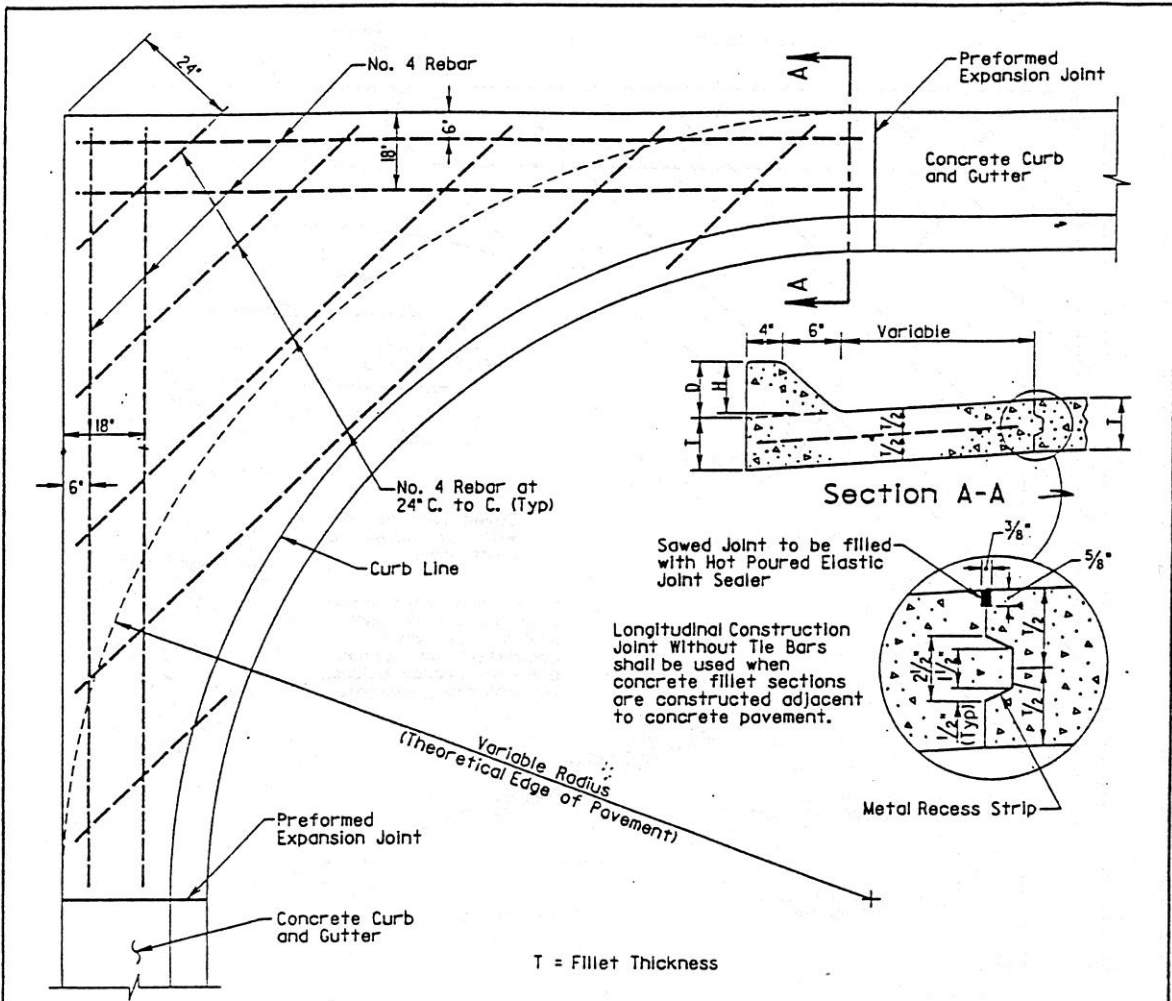

GENERAL NOTES:

Dimensions "D", "H", and "T" shall conform to those shown on the appropriate Curb and Gutter Standard.

All rebars shall be epoxy coated and shall conform to A.S.T.M. A615 Grade 60 and the South Dakota Standard Specifications for Roads and Bridges, Section 480 and 1010. All rebars shall have a minimum of 3" cover.

Class M-6 Concrete shall be used in construction of the fillets. The concrete curb shall be monolithic with the concrete fillet. No separate payment for this curb will be made, same being considered a part of the fillet.

Joints shall be constructed at 10' intervals except when fillets are constructed adjacent to PCC Pavement then the joints shall be extended from edge of pavement through the fillet section as directed by the Engineer.

The cost of all materials, labor and incidentals necessary to complete the same shall be included and absorbed in the contract unit price per Square Yard for Concrete Fillet Section.

July 1, 1992

SPECIFICATION REFERENCE NO. 380	STATE OF SOUTH DAKOTA DEPARTMENT OF TRANSPORTATION PCC FILLET SECTION WITH TYPE F CURB & GUTTER	PLATE NUMBER 380.14
--	--	---------------------------

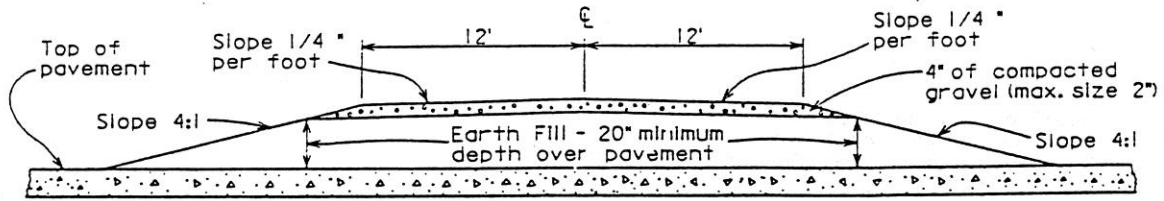

TRANSVERSE SECTION OF CROSSING

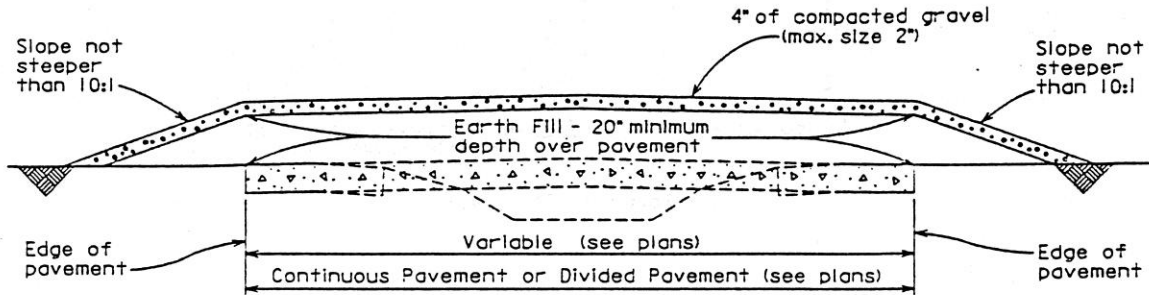

LONGITUDINAL SECTION ALONG CENTERLINE OF CROSSING

GENERAL NOTES:

Temporary Earth Crossing shall be constructed and satisfactorily maintained in accordance with the details shown above. When the need for the crossing no longer exists the contractor shall, at the direction of the Engineer, remove the crossing and dispose of the materials therein to the satisfaction of the Engineer.

Temporary Earth Crossing shall be paid for at the contract unit price per each, in place complete, which price shall be full compensation for furnishing and placing all materials and for all labor, equipment, and incidentals necessary to construct and dispose of the same.

When the plans specify that the fill over the pavement be entirely of gravel, instead of earth and gravel as shown by the details above, all except the upper 4 inches of the gravel may be pit-run gravel. In these cases the item becomes "Temporary Gravel Crossing" instead of "Temporary Earth Crossing", but otherwise the requirements stated above for "Temporary Earth Crossing" shall apply.

May 8, 1991

SPECIFICATION REFERENCE NO. 380	STATE OF SOUTH DAKOTA DEPARTMENT OF TRANSPORTATION TEMPORARY EARTH OR GRAVEL CROSSING	PLATE NUMBER 380.15
--	--	---------------------------

Sawed Joint to be filled with Hot-Poured Elastic Joint Sealer or other Sealer as approved by the Engineer.

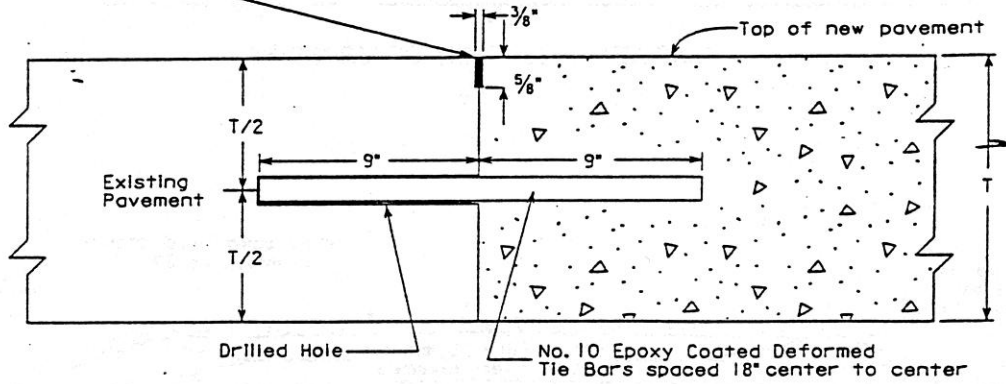

T = Pavement Thickness

GENERAL NOTE:

The tie bar is to be embedded a minimum depth of 9 inches into the existing pavement and anchored with an epoxy resin adhesive.

July 1, 1992

<p>SPECIFICATION REFERENCE NO. 380</p>	<p>STATE OF SOUTH DAKOTA DEPARTMENT OF TRANSPORTATION TIE BAR INSTALLATION IN TRANSVERSE JOINT</p>	<p>PLATE NUMBER 380.16</p>
--	--	------------------------------------

Sawed Joint to be filled with Hot-Poured Elastic Joint Sealer.

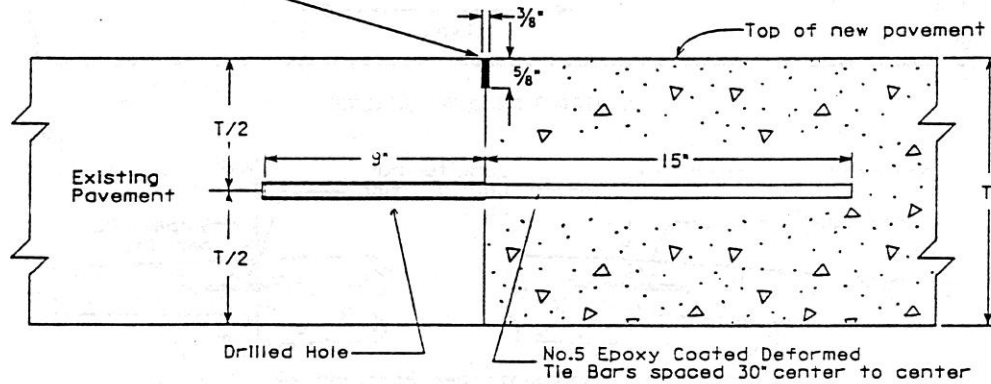

T = Pavement Thickness

GENERAL NOTES:

The tie bar is to be embedded a minimum depth of 9 inches into the existing pavement and anchored with an epoxy resin adhesive.

Tie bars shall be placed a minimum of 15 inches from existing transverse contraction joints.

July 1, 1992

<p>SPECIFICATION REFERENCE NO. 380</p>	<p>STATE OF SOUTH DAKOTA DEPARTMENT OF TRANSPORTATION TIE BAR INSTALLATION IN LONGITUDINAL JOINT</p>	<p>PLATE NUMBER 380.17</p>
--	--	------------------------------------

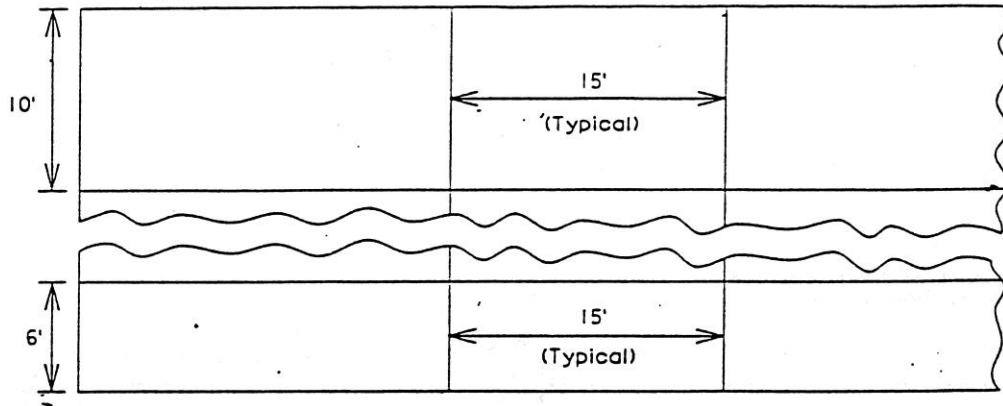

CONTRACTION JOINT SPACING

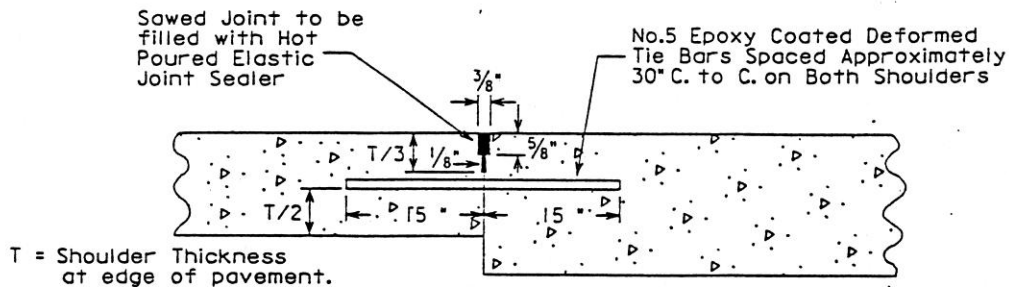
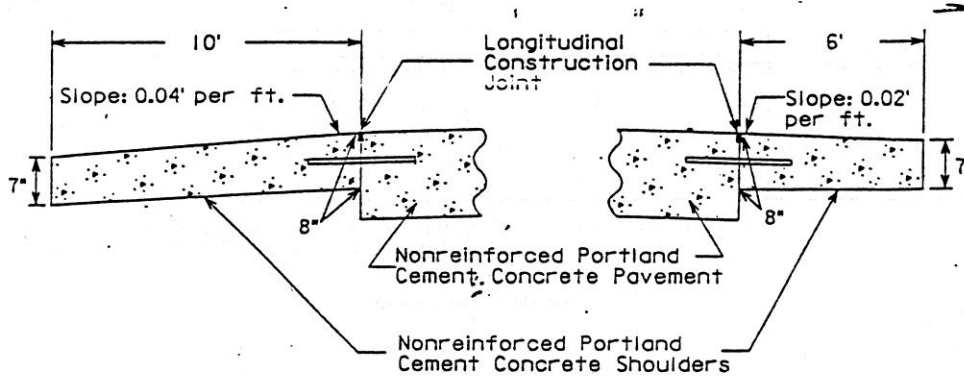

LONGITUDINAL CONSTRUCTION JOINT
(Between Main Line and Shoulder)

GENERAL NOTE:

The first saw cut to control cracking shall be a minimum of 1/3 the depth of the pavement. Additional sawing for widening the saw cut to provide the width for the installation of the Hot-Poured Elastic Joint Sealer will be necessary.

September 23, 1993

SPECIFICATION REFERENCE NO. 380	STATE OF SOUTH DAKOTA DEPARTMENT OF TRANSPORTATION NONREINFORCED PORTLAND CEMENT CONCRETE SHOULDERS	PLATE NUMBER 380.18
--	--	---------------------------